



ALARM CONTROL UNIT FOR  
TOXIC & FLAMMABLE GASES

# INSTRUCTION MANUAL



**DALEMANS®**  
G A S D E T E C T I O N

# DALEMANS®

G A S D E T E C T I O N

Copyright © 2022 DALEMANS S.A.

Revision V1R1 • 09/2022

*Any reproduction, partial or full, of this document by means of any process whatsoever without prior written consent from DALEMANS s.a. is strictly prohibited.*

## **Warning**

*All information contained in this document is non-contractual and **subject to change without notice.***

*We also encourage you to regularly check the availability of a new version on our website: <http://www.dalemans.com>*

*Please contact your distributor in case of doubt,*

## **DALEMANS sa/nv**

*Rue Jules Mélotte, 27A • B-4350 Remicourt (Belgique)  
Tél. +32 19 33 99 43 • Email: [sales@dalemans.com](mailto:sales@dalemans.com)*

# TABLE OF CONTENT

---

<b>1 General remarks</b> .....	<b>5</b>
1.1 Responsibilities - guarantees.....	5
1.2 Safety information.....	6
1.3 Environment .....	7
1.4 Operating Principle .....	7
1.5 Display interface.....	8
1.5.1 LED .....	8
1.5.2 Keypad.....	9
1.5.3 Display.....	9
<b>2 Installation</b> .....	<b>11</b>
2.1 Precautions for Use.....	11
2.2 Placing the U•V6 unit .....	11
2.3 Connecting the control unit.....	12
2.4 Connecting the Detectors.....	13
2.4.1 General .....	13
2.4.2 Two-Wire Current-Loop Detectors.....	13
2.4.3 Three-Wire Current-Loop Detectors .....	14
2.5 Connecting the Relays.....	14
2.6 Connecting the Siren .....	14
2.7 Connecting the Analogue Output .....	15
2.8 Connecting the Power Supply.....	16
2.9 Connecting a Battery .....	16
2.10 First Start-Up .....	17
<b>3 Configuration</b> .....	<b>18</b>
3.1 Unit-Configuration Principle.....	18
3.2 Addressing the Relays.....	18
3.2.1 Standard Factory Settings.....	19
3.2.2 Standard Configurations for Car Parks .....	20
3.2.3 Standard Configurations for Laboratories .....	27
3.3 Target Gases and Alarm Thresholds .....	32
3.3.1 Target gases for car parks .....	33
3.3.2 Target Gases for Laboratories .....	34

<b>4 User menus .....</b>	<b>36</b>
<b>4.1 Main menu.....</b>	<b>36</b>
<b>4.2 Info Menu .....</b>	<b>36</b>
4.2.1 History .....	37
4.2.2 Calibration Age .....	37
4.2.3 Battery Age.....	37
4.2.4 Firmware Version.....	37
4.2.5 Date and Time .....	37
<b>4.3 Configuration Information .....</b>	<b>38</b>
4.3.1 Base standard configuration.....	38
4.3.2 Measurement Channels.....	39
4.3.3 Target Gases .....	41
4.3.4 Relay Configuration .....	42
4.3.5 Fault Menu.....	43
4.3.6 External Alarm Menu .....	45
4.3.7 Analogue Output.....	47
4.3.8 Errors reset mode .....	49
4.3.9 Network Info .....	49
<b>4.4 Statuses Menu .....</b>	<b>50</b>
<b>4.5 Test Menu.....</b>	<b>51</b>
<b>5 Service menu .....</b>	<b>52</b>
<b>5.1 Protected Access .....</b>	<b>52</b>
<b>5.2 Advanced System Tests .....</b>	<b>53</b>
5.2.1 Outputs Tests.....	53
5.2.2 Analogue Output Test.....	54
5.2.3 Simulating a Detector .....	54
5.2.4 Switching to the Battery .....	55
<b>5.3 Configuration Menu.....</b>	<b>56</b>
5.3.1 Configuring the Measurement Channels.....	56
5.3.2 Network Configuration .....	57
<b>5.4 Maintenance Management.....</b>	<b>59</b>
5.4.1 Maintenance Interval.....	60
5.4.2 Renewing the Validity of the Calibration.....	60
<b>6 Spare Parts and Options .....</b>	<b>62</b>
<b>7 Target gases.....</b>	<b>63</b>

<b>8 Product specifications .....</b>	<b>64</b>
<b>A. Event messages .....</b>	<b>65</b>
<b>B. Error messages .....</b>	<b>68</b>
<b>C. Predefined locations .....</b>	<b>70</b>
<b>D. Characters available for text edition .....</b>	<b>71</b>
<b>E. User menu diagram .....</b>	<b>72</b>
<b>F. Service menu diagram .....</b>	<b>74</b>

# 1 GENERAL REMARKS

---

## 1.1 Responsibilities - guarantees

The installer is required to respect **CE** standards and installation provisions.

The installation must be carried out by qualified personnel.

All our equipment is tested and inspected in our workshops before shipping.

This manual must be read carefully by anyone who is or will be responsible for the installation, use and/or maintenance of this equipment. The guarantee offered by **DALEMANS sa/nv** will be void if this equipment is not installed, used and maintained in compliance with these instructions, warnings and limits of use.

By following these instructions, you guarantee the proper working of the equipment. Please contact **DALEMANS sa/nv** for any information about the use or maintenance of this product.

**ONLY** use original **DALEMANS sa/nv** parts when performing maintenance on the equipment as described in this manual. Otherwise you may seriously alter the equipment's performances.

Any repair or maintenance performed without respecting the procedures described in this manual or without help from our after-sales service may prevent the equipment from working correctly and, as a result, prevent guaranteeing the safety of the occupants of the building and installations.

This equipment must be installed indoor, in a clean and dry area. Please use a screen (box) to avoid any projections of water or polluting agents. Don't hesitate to contact **DALEMANS sa/nv** for any additional information concerning the use of maintenance of this product.

**DALEMANS sa/nv** cannot be held responsible for any direct or indirect damage as well as any direct and indirect monetary damages resulting from the failure to comply with these guidelines.



**DALEMANS sa/nv** guarantees that this product is free from manufacturing defects and agrees, at its sole discretion, to repair or replace any component which is defective or likely to become so in the context of normal use during the warranty period specified in the general terms of sale.

This guarantee does not cover elements such as batteries, fuses or any other component provided by a third party.

Claims concerning the **DALEMANS sa/nv** product guarantee must be made in the guarantee period specified above and within 5 calendar days of the discovery of the problem. Please contact your **DALEMANS sa/nv** after-sales service to register your claim.

For any additional information, please refer to **DALEMANS sa/nv** general conditions available on request.

## 1.2 Safety information

Symbol	Description
	Protective ground terminal
	Warning : risk of electric shock
	Warning : refer to instruction manual

---

 Do not open the equipment without disconnecting mains power supply first

---

The installation and commissioning of U•V6 control unit must be performed by qualified personnel only. This qualified personnel is trained and accredited by **DALEMANS sa/n**. During installation, refer to the standards in application.

Should the equipment be installed or used in a manner not specified by **DALEMANS sa/nv**, the protection provided by the equipment may be impaired.

Modification, disassembling and total or partial destruction of this equipment may invalidate the essential safety requirements of the whole plant.

For commissioning, please contact **DALEMANS sa/nv** to arrange an appointment.

## 1.3 Environment



The presence of the crossed-out wheeie bin logo on this product means that you are required to respect the regulations in force concerning the collection and recycling of waste electrical and electronic waste.

These provisions aim to preserve the natural resources used to produce this product and to avoid the dispersal of substances which are potentially harmful to the environment and human health.

Once this product reaches the end of its life, you **MUST** discard it by taking it to an approved collection centre for the recycling of electrical and electronic equipment.

For more information on collection and recycling centres in your region, please contact your local or regional administration.

## 1.4 Operating Principle

The U•V6 is a control unit for detecting toxic and/or inflammable gases in a commercial or light industrial building (e.g. underground car parks), so that action can be taken. It allows ventilation to be actively regulated, in particular. It has six detection inputs and up to four alarm thresholds that can be configured independently for each input.

The U•V6 unit must be connected to one or more gas detectors. A gas detector is a stationary device that sends the U•V6 a constant signal that is proportional to the concentration of gas detected in the air.

The unit can send commands to one or more pieces of connected safety equipment when the configured alarm thresholds are reached, e.g., to do the following:

- control the ventilation (air blowers or extractors)
- cause a siren to sound
- cause a LED warning panel to light up
- send a command to a CTM (Centralised Technical Management) system

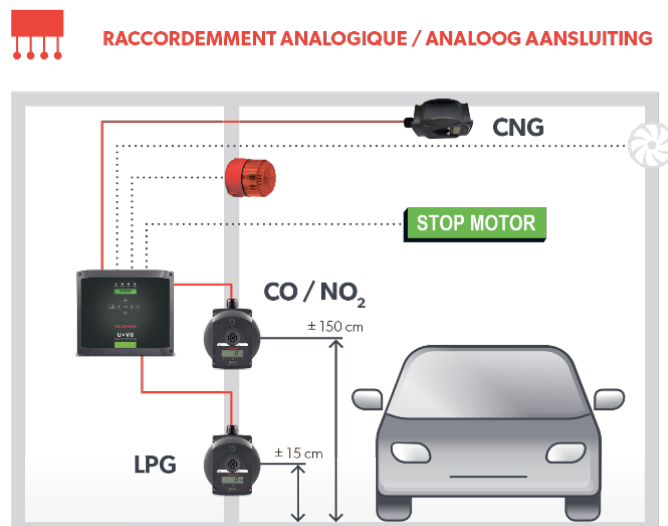

The U•V6 unit also has internal fault management. Notification is sent via a relay signalling a technical fault once any unusual use of the unit or a detector is detected. This function thus ensures the reliability of the gas-detection system installed.



The status of the U•V6 unit and the triggering of each of the functions presented may be viewed via the front panel of the unit at any point in time:

- The display has a backlight that varies in colour depending on the status of the U•V6 unit and shows a message explaining the status.
- There is a set of colour LEDs.
- There is a resettable buzzer which is triggered when the fault or alarm functions are triggered.

## 1.5 Display interface

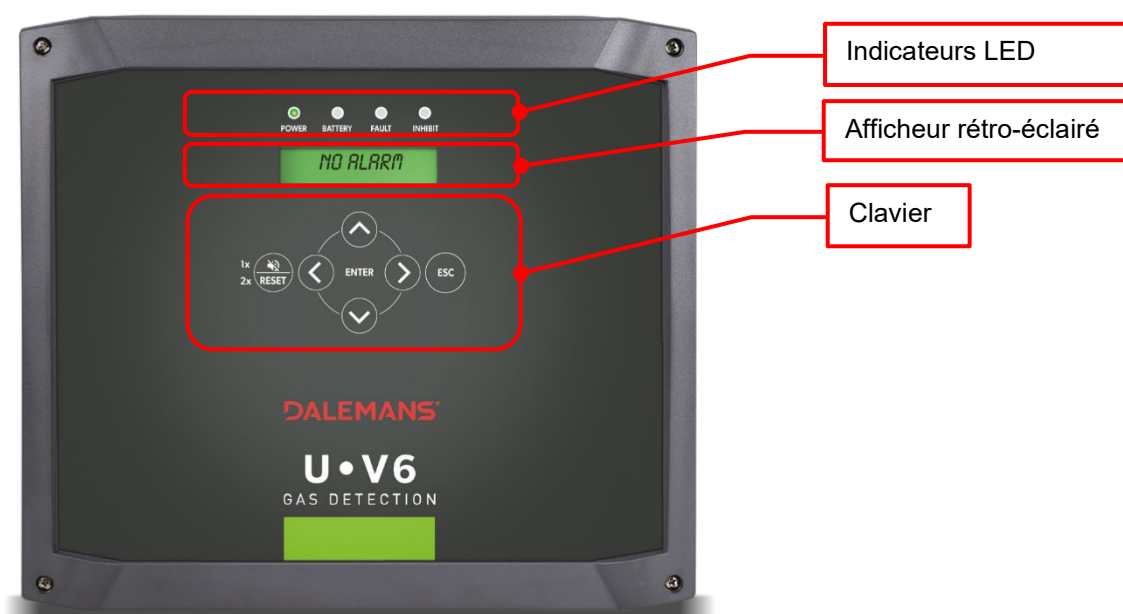

### 1.5.1 LED

LED indicators	
« <b>Power</b> » LED	The control unit is powered on
« <b>Battery</b> » LED	A battery is installed and correctly detected
« <b>Fault</b> » LED	There is at least one active fault condition.
« <b>Inhibit</b> » LED	The control unit is in a special state: gas concentration measurements and alarm management are still running; the alarm statuses are not updated. This mode automatically exits after 15min without any user interaction.

## 1.5.2 Keypad

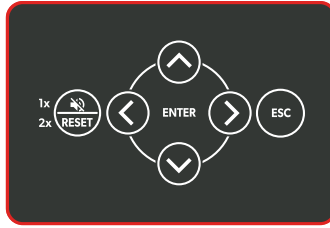

↑ ↓	Allows the user to move around a menu or a selection
→	Allows the user to enter a sub-menu or launch the action associated with the menu item selected
←	Allows the user to exit a sub-menu and return to the parent menu
ENTER	Allows the user to enter configuration mode, to confirm a change of settings or to launch the action associated with the menu item selected
ESC	Allows the user to exit the configuration menus entirely or cancel the modification of the settings in progress and return to the parent menu
RESET 1 x	Allows the user to turn off the buzzer and the siren output
RESET 2 x	Allows the user to do the following: <ul style="list-style-type: none"> <li>- reset an alarm, on the condition that the alarm is no longer active</li> <li>- reset the faults for which there are still notifications, but which are no longer valid.</li> </ul>

## 1.5.3 Display

The current status of the U•V6 unit is indicated by the **messages** on the display and the colour of the backlighting.

Backlighting	Off	Green	Yellow	Red
Mode	Standby	No Alarm	Maintenance	Alarm
Message	Looped Display: <ul style="list-style-type: none"> <li>• <b>No Alarm</b> indicates that there are no active alarms.</li> <li>• Maintenance Date: <b>Next Maintenance</b></li> <li>• <b>Gas Concentration Values</b> for each of the detectors.</li> </ul>		Maintenance interval exceeded: <p><b>Maintenance required .</b></p> <p><b>Technical Fault</b></p> Looped Display: <ul style="list-style-type: none"> <li>• List of <b>faults and technical faults</b></li> </ul>	Looped display of the alarms that have been triggered. The highest alarm level per type of gas monitored is displayed. <p>The ID of the detector, the alarm level and the gas concentration measured is shown for each of the alarms displayed.</p>

**i** Only alarm messages are displayed when an alarm has been triggered, so any messages associated with technical faults are no longer shown.

### a) Alarm mode (gas detected)

The unit enters into alarm mode when one or more alarm conditions have been met. The screen turns RED, indicating the alarm level of the highest active alarm.

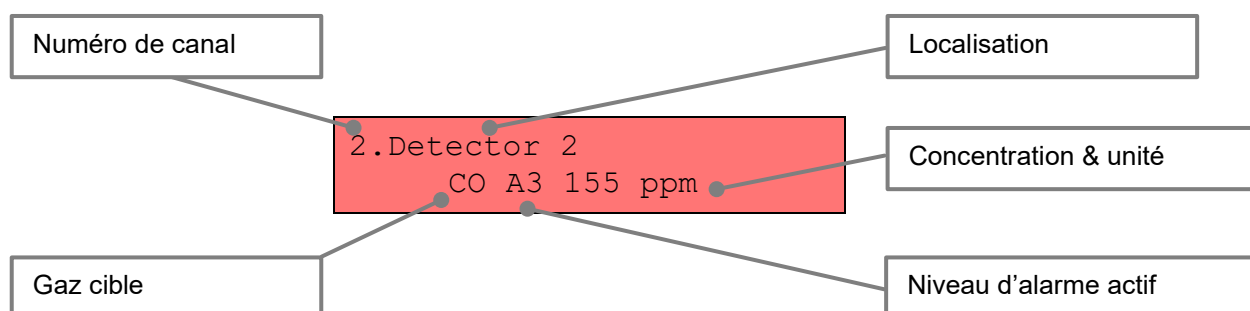

The system can only exit alarm mode when all the alarm conditions have been reset.

### b) Fault mode

The system can enter back-up mode when no alarm conditions have been met, but one or several fault conditions have been.

The diagram shows a central yellow rectangular box representing the fault mode screen. Inside the box, the text reads "2.Detector 2" on the top line and "Sensor error" on the bottom line.

### c) Normal mode

Normal mode is reached if, and only if, the following conditions have been met:

- No alarm conditions have been met
- There are no faults

In such a case, the screen is GREEN and states 'No alarm':

The diagram shows a central green rectangular box representing the normal mode screen. Inside the box, the text reads "No alarm".

### d) Standby mode

When there are no gas alarms or fault messages, the backlighting of the display enters into standby mode after 60 seconds.

The system automatically exits standby mode when one of the following occurs:

- keyboard action
- detection of an alarm
- appearance of a technical fault

## 2 INSTALLATION

---

### 2.1 Precautions for Use

For your safety, ensure that you are working **on a device that is powered off** before you do anything!

- ⚠ The housing of the U•V6 unit may only be opened by qualified technicians.
- ⚠ The U•V6 unit must be placed in a room that does not have an explosive atmosphere and must always be easy to access.

The housing of the U•V6 unit can be inverted. It can be used in such a way that electric cables can be inserted from the top, or in such a way that they can be inserted from the bottom. However, in order to guarantee optimal sealing, it is recommended that you always insert the cables from the bottom.

The housing of the device is **IP65**-certified and is therefore protected against the presence of dust and water, provided that the installation instructions are followed.

The housing has a number of machined apertures. You will need to clear these machined apertures with a flat screwdriver and hammer in order to insert the cable glands.

#### ⚠ Important note:

Never place the U•V6 unit, the siren and the detector cables in the vicinity of:

- high-voltage cables or power cables;
- transmitters or coaxial cables;
- welding stations or frequency regulators.

### 2.2 Placing the U•V6 unit

The U•V6 unit must be placed on a smooth, flat surface. Two fixing systems, a drilling plan and a quick installation guide are supplied with the device. You can choose to fix the unit using the housing or the four feet provided.

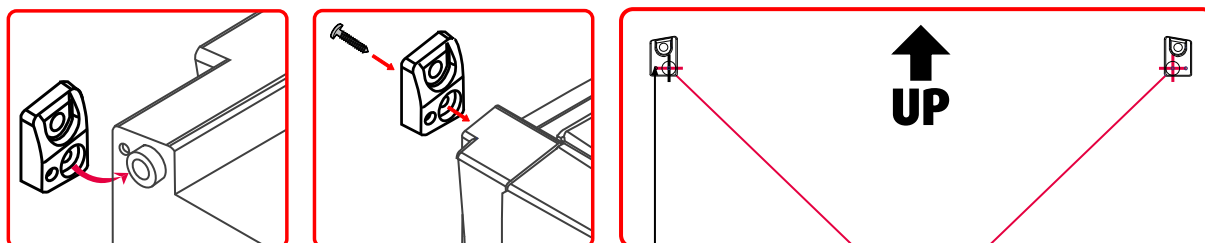

It is also possible to fix the U•V6 unit on a DIN rail (optional). Please contact your **DALEMANS** representative for more information.

If you choose to fix the device without using the feet, attach the housing via the four holes provided for this purpose to the four corners of the housing using a PZ2 screwdriver that is at least 150 mm long.

See the quick installation guide provided for the different steps.

## 2.3 Connecting the control unit

The unit must be installed and the electrical connections hooked up by a qualified technician, in accordance with the instructions given in this manual and on the diagram on the back of the cover of the U•V6 unit.

**⚠** A circuit breaker (2 pins, 6A, 250V (AC)) must be placed on the live and the neutral. See the wiring example below.

It is recommended that you place the circuit breaker in the vicinity of the equipment.

Any installation must comply with the applicable local standards and regulations, in particular as they pertain to the type of cable and the cross-sectional area of the wires to be used.

Ensure that the wires are securely connected to the connectors when connecting the electrical terminals. Use a maximum torque of 0.60 Nm. To ensure electrical safety, the wires that go from the cable glands on the housing to the terminals on the board must not be longer than 70 mm.

It is recommended that you always use wires with crimp ends, in order to avoid any risk of bad electrical contacts.

### Example Connection Diagram for the U•V6 Unit:

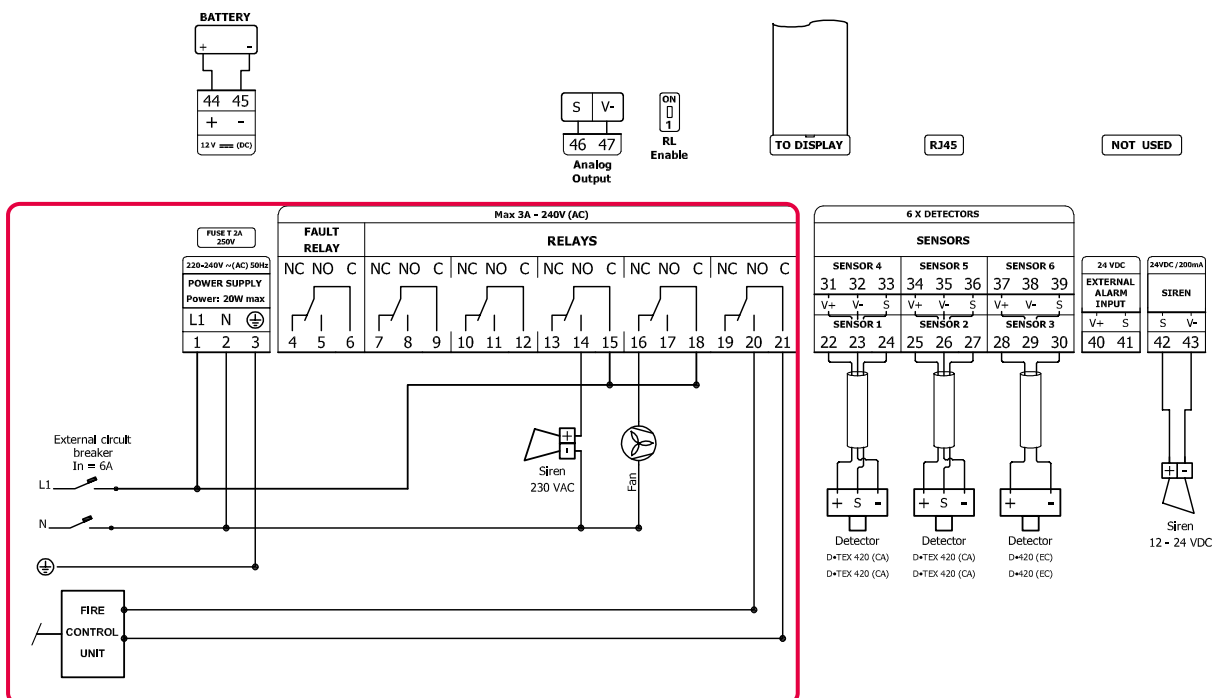

## 2.4 Connecting the Detectors

### 2.4.1 General

The terminals coming from each detector must be connected to the U•V6 unit in the following order:

Bornes D•420 CA/IR/SC (3 fils)	Bornes D•420 EC (2 fils)	Bornes central U•V6
+	+	V+
-		V-
S	-	S

EC: Électrochimique (2 fils) - IR: Infrarouge (3 fils) - SC: Semi-conducteur (3 fils) - CA: Catalytique (3 fils)

(see Paragraphs 2.4.2 and 2.4.3 below for more details)

- ❗ The cables that connect the detectors and the U•V6 unit should not be more than 300 m long.
- ❗ In the event that the U•V6 unit is installed in an environment that contains sources of strong electromagnetic interference (transmitters, welding stations, switching relays, HF transmitters, cable runs or computer networks, etc.), it is preferable to use shielded cables to connect the detectors.

- ⚠ Never use two or more wires to increase the cross-sectional area of the wire. The cable must be one length of cable (without connections) and properly connected to the appropriate terminals. Use a maximum torque of 0.60 Nm.
- ⚠ Never place a detector cable next to a coaxial cable or a power cable and definitely never in the same bundle or cable run.

### 2.4.2 Two-Wire Current-Loop Detectors

Use a dual-conductor flex cable with a cross-sectional area of between 0.75 and 1.5 mm<sup>2</sup> to connect the D•420 electrochemical detector (e.g., CO and NO<sub>2</sub>. See the diagram below).

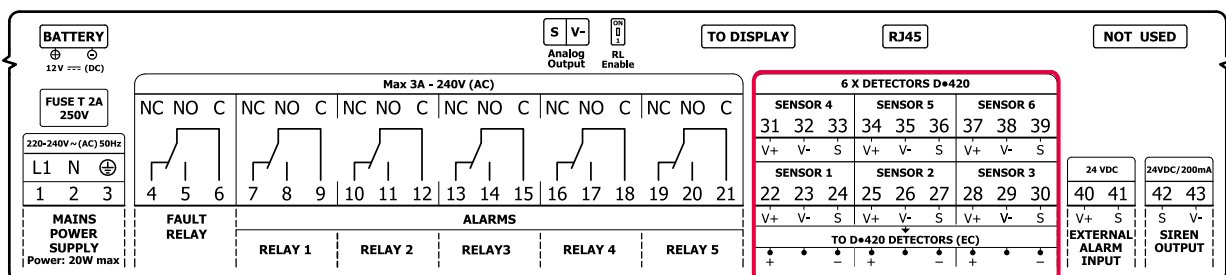

## 2.4.3 Three-Wire Current-Loop Detectors

Use a triple-conductor flex cable with a cross-sectional area of between 0.75 and 1.5 mm<sup>2</sup> to connect the D•420 infrared detector and the D•TEX 420 catalytic detector (e.g., LPG and CNG. See the diagram below).

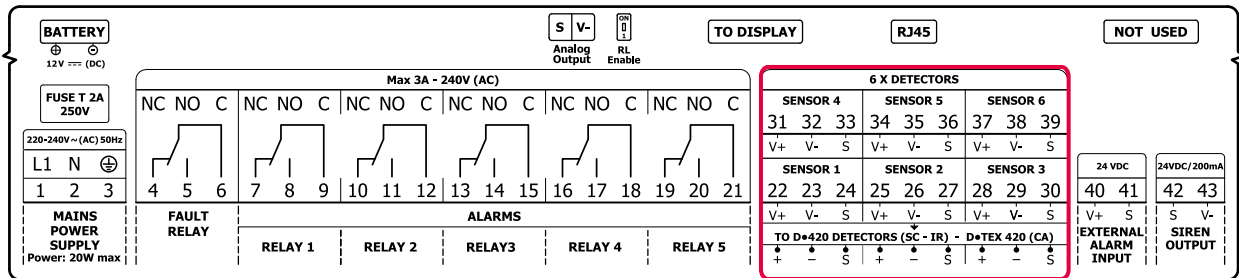

## 2.5 Connecting the Relays

The U•V6 unit has five relays that can be addressed by the alarms and a technical-fault relay. Different types of devices can be connected to these relays, such as air blowers or extractors, sirens, LED warning signs or flashing lights, etc.

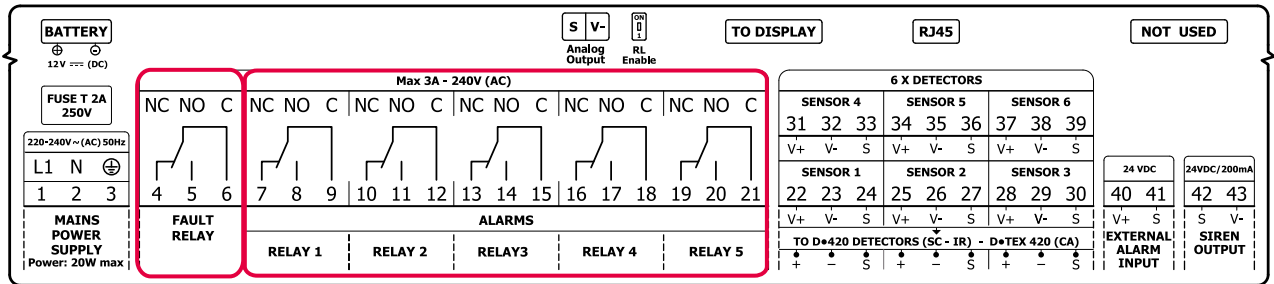

## 2.6 Connecting the Siren

Connect the **S** and **V-** terminals on the siren to the U•V6 unit (Terminals 42 and 43, respectively). Respect the polarity to avoid damaging the siren.

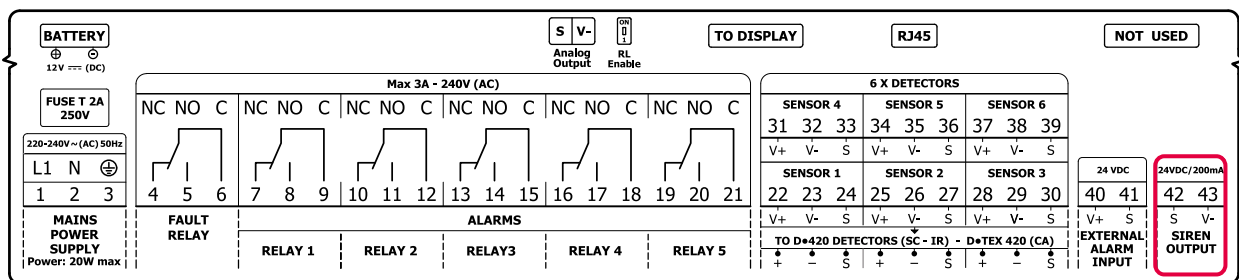

The cables used to connect the siren must meet the same requirements as the detector cable (see Connecting the Detectors).

See the operation manual for the siren for instructions on how to connect the siren and configure its tone.

## 2.7 Connecting the Analogue Output

Connect the **S** and **V-** terminals on the analogue output to close the circuit. In current-loop mode, the current leaves via terminal **S** and returns via terminal **V-**.

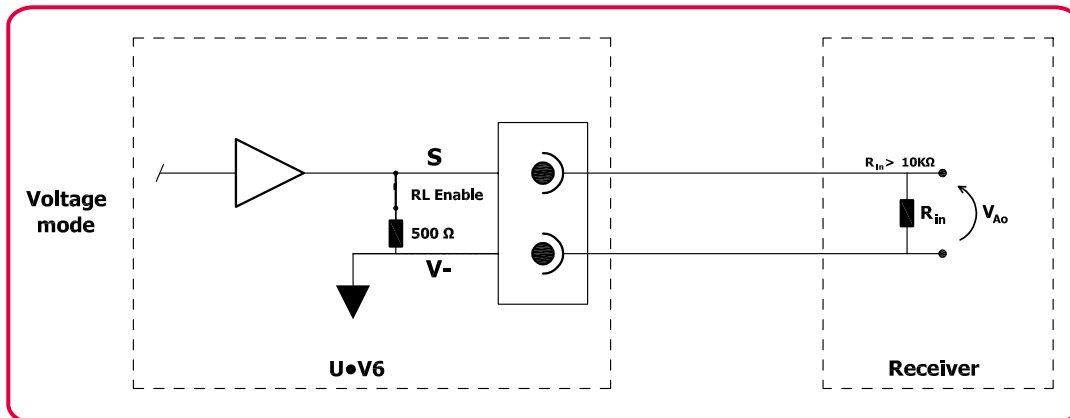
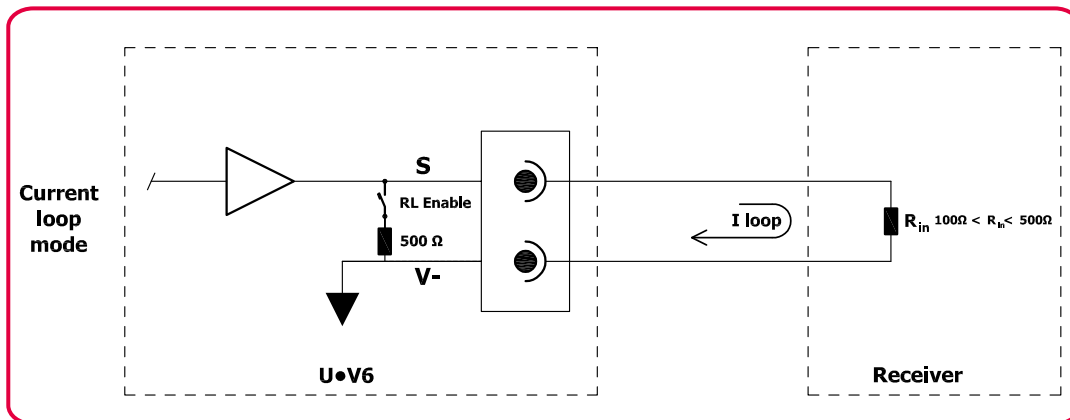
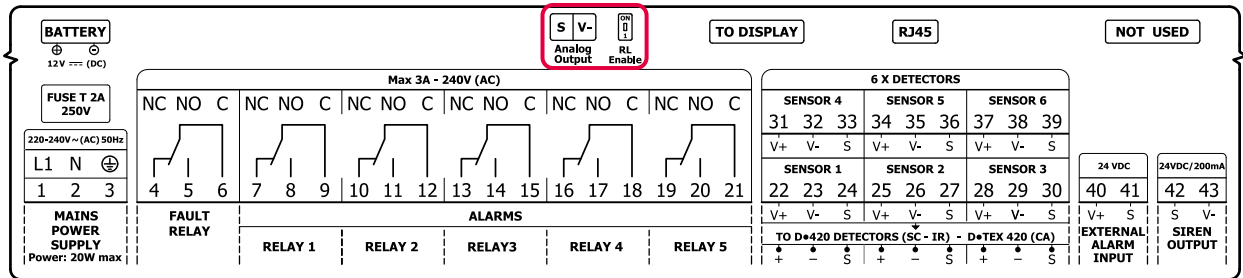

The analogue output is configured as follows before leaving the factory:

- In 4-20 mA current-loop mode
- The output signal corresponds to the maximum value of the 6 input channels
- The output gain ratio is 1:1 of the detectors' measurement range. A full-scale measurement of the detector is shown as 20 mA on the analogue output signal

The user can change the unit from a current-loop signal mode to a voltage-signal mode by toggling the **RL Enable** switch:

- The **ON** position of the **RL Enable** switch transforms the output signal to a voltage signal, by adding a 500Ω shunt resistor.
- The other position (the **OFF** position) of the **RL Enable** load-resistor switch leaves the analogue output in current-loop mode.



- ❗ The operation of the current-loop mode might be impaired if the piece of equipment connected has an input impedance of less than **100Ω** or greater than **500Ω**.
- ❗ The operation of the voltage mode might be impaired if the piece of equipment connected has a low input impedance (less than **10kΩ**)

## 2.8 Connecting the Power Supply

Connect the **earth to terminal 3** and then the **230V mains voltage to terminals 1 and 2 on the terminal**; see the box below.

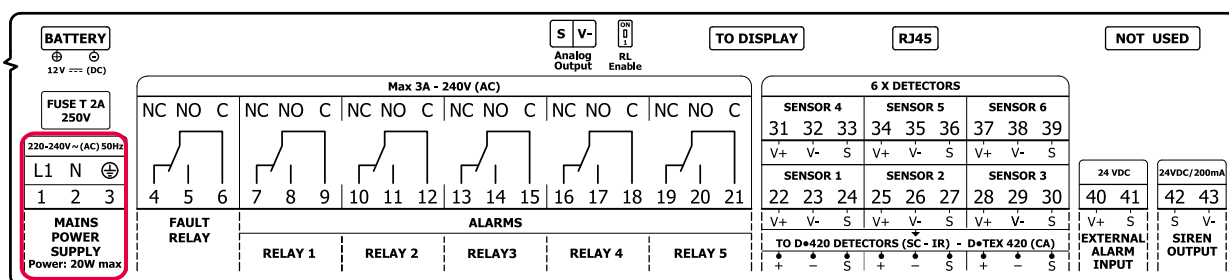

It must be possible to electrically isolate the U•V6 unit for maintenance (protection via a circuit breaker or double pole switch).

The power supplies for the U•V6 unit and the different devices must be connected to the same circuit. Ensure that the power conductors are always attached together and kept separate from the low-voltage conductors.

The power cables for the 230 V part must have a minimum cross-sectional area of **1.5 mm<sup>2</sup>**.

- ⚠ The U•V6 unit is a Class-I device. The U•V6 unit must always be connected to the earth, in accordance with the instructions given in this manual.

## 2.9 Connecting a Battery

The U•V6 unit has a 'smart' battery charger. A proportional, controlled charge prevents the early wear and tear or damage of the battery connected.

- ❗ **A compatible battery, which is sold separately, comes as standard with the U•V6 unit. Please contact your DALEMANS representative to order a battery.**

The "**Battery**" LED on the U•V6 central unit flashes only if :

- the battery voltage is too low,
- the battery is discharged,
- the battery is defective.

- 
- i** The useful lifespan of a standard battery is estimated at four years. It is essential to replace it after that. If a battery is defective, its charge is inhibited to avoid damaging it.
- 

Ensure that the U•V6 unit is not under power before starting with the installation procedure.

Clear the front panel by unscrewing the four corners and disconnecting the flat connection cable.

Then, place the battery in the housing provided for this purpose, before following the steps below:

1. Connect the battery, respecting the polarity.  
The U•V6 unit turns on.  
The “**Power**” LED stays off.  
The “**Power Failure**” message appears and the “**Fault**” LED lights up.  
The “**Battery**” LED lights up as soon as the U•V6 unit detects the battery.  
This detection operation may take a few sections.
  2. Reconnect the flat connection cable.
  3. Turn the power for the U•V6 unit back on.
  4. The fault message disappears after a few seconds. The “**Power**” and “**Battery**” LEDs light up.
- 

- i** The U•V6 unit may place itself in an unknown status during this operation. As a result, it may be necessary to restart it correctly by pressing the Reset button on the motherboard.
- 

## 2.10 First Start-Up

Before you power on your U•V6 unit, please ensure that the terminals have been tightened properly and the power voltage is in the acceptable operating range for the U•V6 unit.

---

**⚠** Please contact **DALEMANS sa/nv** to set up a commissioning appointment.

---

The LEDs on the motherboard must light up when the device is powered on. It is important that the user checks that these are all green and not flashing, except for the yellow LED on the right-hand side of the motherboard, which should flash on and off at one-second intervals.

Immediately after the unit is powered on, the LCD screen on the unit must turn blue and the buzzer should sound a short, uninterrupted sound.

All activated detection channels are in a “warm-up” state when the unit is turned on. The measurements on a channel in a warm-up state are ignored. The warm-up state has a finite duration which depends on the target gas configured.

# 3 CONFIGURATION

---

The configuration for the U•V6 unit comprises a set of menus that allows the system settings to be configured. The user can access these menus, regardless of the status of the U•V6 unit, by pressing **ENTER** on the keyboard (if the display is in standby, the user should first exit standby mode by pressing any key). Once in this mode, the display backlighting **turns blue**.

The U•V6 unit automatically exits configuration mode after an idle period of 60 seconds (a period in which no action is performed using the keyboard) and returns to the appropriate mode: normal mode, if no faults or alarms have been signalled; fault mode, if a fault, but no alarms, have been signalled; or alarm mode if an alarm has been signalled.

## 3.1 Unit-Configuration Principle

The factory settings for the U•V6 unit are intended for underground car parks and may be changed depending on the intended use.

All the channels are deactivated in the factory. A detector-detection script must be run, so that all the channels to which detectors have been connected can be activated (see **Paragraph 6.4.1 Spotting the Detectors**).

A gas-detection system controlled by the U•V6 unit must be configured as follows:

1. Detect the detectors and activate the input channels
2. Select the appropriate "standard config."
3. **[Optional]** Select the target gases and alarm thresholds for each input channel
4. **[Optional]** Adjust the settings specific to the installation.

---

 These operations require the intervention of qualified technicians. Contact **DALEMANS sa/nv** for more information.

---

## 3.2 Addressing the Relays

Relay addressing involves connecting the alarm conditions configured with actions to open or close contacts on the alarm relays. Depending on the requirements of the installation, a standard configuration can be selected and, as a result, the appropriate devices can be activated in the event of a gas detection.

These standard configurations come as presets, which are stored in the unit's memory. A technician, who has been trained and certified by **Dalemans sa/nv**, can activate the most appropriate standard configuration for the installation during commissioning.

- ① The PENxx standard configurations have been designed in accordance with EN 50545-1. However, any subsequent modification may impact compliance with this standard. Please contact your **DALEMANS sa/nv** representative for more information.

### 3.2.1 Standard Factory Settings

The **PEN01** configuration is active on the U•V6 unit when it leaves the factory and is delivered:

<b>PEN01</b>			F	R1	R2	R3	R4	R5
		<b>FAULT</b>	✓					
<b>Channel #</b>	<b>Target gas &amp; range</b>	<b>Power Failure</b>	✓					
Channel 1	CO 300ppm	A1		✓	✓			
		A2		✓	✓	✓	✓	
		A3		✓	✓	✓	✓	✓
		-						
Channel 2	CO 300ppm	A1		✓	✓			
		A2		✓	✓	✓	✓	
		A3		✓	✓	✓	✓	✓
		-						
Channel 3	CO 300ppm	A1		✓	✓			
		A2		✓	✓	✓	✓	
		A3		✓	✓	✓	✓	✓
		-						
Channel 4	CO 300ppm	A1		✓	✓			
		A2		✓	✓	✓	✓	
		A3		✓	✓	✓	✓	✓
		-						
Channel 5	CO 300ppm	A1		✓	✓			
		A2		✓	✓	✓	✓	
		A3		✓	✓	✓	✓	✓
		-						
Channel 6	CO 300ppm	A1		✓	✓			
		A2		✓	✓	✓	✓	
		A3		✓	✓	✓	✓	✓
		-						

**A1, A2 and A3** represent the respective alarm conditions for each input channel.

**F, R1, R2, R3, R4 and R5** represent the fault relay and the five alarm relays that can be addressed.

A ✓ symbol with an intersecting row and column indicates that the alarm condition in the row, if met, will activate the relay in the corresponding column.

#### Configuration description:

- The six detector input channels are configured to detect CO with a range of measurement of 300 ppm
- Single zone: identical alarm conditions all address the same relay
- The five programmable relays are addressed as follows:
  - Relays 1 & 2 are addressed to level-one alarms on the six input channels

- Relays 3 & 4 are addressed to level-two alarms on the six input channels
- Relay 5 is addressed to level-three alarms on the six input channels
- The fault relay works in failsafe mode
- The alarm relays are configured in non-failsafe mode
- The input for an external alarm is not enabled
- The analogue output is enabled, with a 4-20 mA, single-gain current loop

**i** Please contact a **DALEMANS sa/nv** representative for more details about the other possible standard configurations.

### 3.2.2 Standard Configurations for Car Parks

#### a) Standard Configuration PEN01

See standard factory settings

#### b) Standard Configuration PEN02

Variation of PEN01: one zone with two relays for alarm levels A2 and A3 and target gases for car parks.

<b>PEN02</b>			F	R1	R2	R3	R4	R5
		<b>FAULT</b>	✓					
<b>Channel #</b>	<b>Target gas &amp; range</b>	<b>Power Failure</b>	✓					
Channel 1	CO 300ppm	A1		✓				
		A2		✓	✓	✓		
		A3		✓	✓	✓	✓	✓
		-						
Channel 2	CO 300ppm	A1		✓				
		A2		✓	✓	✓		
		A3		✓	✓	✓	✓	✓
		-						
Channel 3	CO 300ppm	A1		✓				
		A2		✓	✓	✓		
		A3		✓	✓	✓	✓	✓
		-						
Channel 4	CO 300ppm	A1		✓				
		A2		✓	✓	✓		
		A3		✓	✓	✓	✓	✓
		-						
Channel 5	CO 300ppm	A1		✓				
		A2		✓	✓	✓		
		A3		✓	✓	✓	✓	✓
		-						
Channel 6	CO 300ppm	A1		✓				
		A2		✓	✓	✓		
		A3		✓	✓	✓	✓	✓
		-						

c) Standard Configuration PEN03

Variation of PEN01: one zone with two relays for alarm levels A1 and A3.

<b>PEN03</b>		F	R1	R2	R3	R4	R5
		✓					
Channel #	Target gas & range	Power Failure	✓				
Channel 1	CO 300ppm	A1		✓	✓		
		A2		✓	✓	✓	
		A3		✓	✓	✓	✓
		-					
Channel 2	CO 300ppm	A1		✓	✓		
		A2		✓	✓	✓	
		A3		✓	✓	✓	✓
		-					
Channel 3	CO 300ppm	A1		✓	✓		
		A2		✓	✓	✓	
		A3		✓	✓	✓	✓
		-					
Channel 4	CO 300ppm	A1		✓	✓		
		A2		✓	✓	✓	
		A3		✓	✓	✓	✓
		-					
Channel 5	CO 300ppm	A1		✓	✓		
		A2		✓	✓	✓	
		A3		✓	✓	✓	✓
		-					
Channel 6	CO 300ppm	A1		✓	✓		
		A2		✓	✓	✓	
		A3		✓	✓	✓	✓
		-					

d) Standard configuration PEN04

Base standard configuration for two-zone systems. Relay 5 is addressed to A3-level alarms for both zones.

<b>PEN04</b>		F	R1	R2	R3	R4	R5
	<b>FAULT</b>	✓					
<b>Channel #</b>	<b>Target gas &amp; range</b>	<b>Power Failure</b>	✓				
<b>Channel 1</b>	<b>CO 300ppm</b>	<b>A1</b>		✓			
		<b>A2</b>		✓	✓		
		<b>A3</b>		✓	✓		
		-					✓
<b>Channel 2</b>	<b>CO 300ppm</b>	<b>A1</b>		✓			
		<b>A2</b>		✓	✓		
		<b>A3</b>		✓	✓		
		-					✓
<b>Channel 3</b>	<b>CO 300ppm</b>	<b>A1</b>		✓			
		<b>A2</b>		✓	✓		
		<b>A3</b>		✓	✓		
		-					✓
<b>Channel 4</b>	<b>CO 300ppm</b>	<b>A1</b>			✓		
		<b>A2</b>			✓	✓	
		<b>A3</b>			✓	✓	✓
		-					
<b>Channel 5</b>	<b>CO 300ppm</b>	<b>A1</b>			✓		
		<b>A2</b>			✓	✓	
		<b>A3</b>			✓	✓	✓
		-					
<b>Channel 6</b>	<b>CO 300ppm</b>	<b>A1</b>			✓		
		<b>A2</b>			✓	✓	
		<b>A3</b>			✓	✓	✓
		-					

e) Standard Configuration PEN05

Variation of PEN04: two zones with four detectors in Zone 1 and two detectors in Zone 2.

PEN05		F	R1	R2	R3	R4	R5
		FAULT	✓				
Channel #	Target gas & range	Power Failure	✓				
Channel 1	CO 300ppm	A1		✓			
		A2		✓	✓		
		A3		✓	✓		✓
		-					
Channel 2	CO 300ppm	A1		✓			
		A2		✓	✓		
		A3		✓	✓		✓
		-					
Channel 3	CO 300ppm	A1		✓			
		A2		✓	✓		
		A3		✓	✓		✓
		-					
Channel 4	CO 300ppm	A1		✓			
		A2		✓	✓		
		A3		✓	✓		✓
		-					
Channel 5	CO 300ppm	A1			✓		
		A2			✓	✓	
		A3			✓	✓	✓
		-					
Channel 6	CO 300ppm	A1			✓		
		A2			✓	✓	
		A3			✓	✓	✓
		-					



f) Standard configuration PEN06

Variation of PEN04: two zones with five detectors in Zone 1 and one detector in Zone 2

<b>PEN06</b>			F	R1	R2	R3	R4	R5
		<b>FAULT</b>	✓					
<b>Channel #</b>	<b>Target gas &amp; range</b>	<b>Power Failure</b>	✓					
<b>Channel 1</b>	<b>CO 300ppm</b>	<b>A1</b>		✓				
		<b>A2</b>		✓	✓			
		<b>A3</b>		✓	✓			✓
		<b>-</b>						
<b>Channel 2</b>	<b>CO 300ppm</b>	<b>A1</b>		✓				
		<b>A2</b>		✓	✓			
		<b>A3</b>		✓	✓			✓
		<b>-</b>						
<b>Channel 3</b>	<b>CO 300ppm</b>	<b>A1</b>		✓				
		<b>A2</b>		✓	✓			
		<b>A3</b>		✓	✓			✓
		<b>-</b>						
<b>Channel 4</b>	<b>CO 300ppm</b>	<b>A1</b>		✓				
		<b>A2</b>		✓	✓			
		<b>A3</b>		✓	✓			✓
		<b>-</b>						
<b>Channel 5</b>	<b>CO 300ppm</b>	<b>A1</b>		✓				
		<b>A2</b>		✓	✓			
		<b>A3</b>		✓	✓			✓
		<b>-</b>						
<b>Channel 6</b>	<b>CO 300ppm</b>	<b>A1</b>				✓		
		<b>A2</b>				✓	✓	
		<b>A3</b>				✓	✓	✓
		<b>-</b>						

g) Standard configuration PEN07

Variation of PEN04: two zones with three detectors in each zone; relay 1 is addressed to A1 alarms in both zones:

<b>PEN07</b>		F	R1	R2	R3	R4	R5
	<b>FAULT</b>	✓					
<b>Channel #</b>	<b>Target gas &amp; range</b>	<b>Power Failure</b>	✓				
Channel 1	CO 300ppm	A1	✓				
		A2	✓	✓			
		A3	✓	✓	✓		
		-					
Channel 2	CO 300ppm	A1	✓				
		A2	✓	✓			
		A3	✓	✓	✓		
		-					
Channel 3	CO 300ppm	A1	✓				
		A2	✓	✓			
		A3	✓	✓	✓		
		-					
Channel 4	CO 300ppm	A1	✓				
		A2	✓			✓	
		A3	✓			✓	✓
		-					
Channel 5	CO 300ppm	A1	✓				
		A2	✓		✓		
		A3	✓		✓	✓	
		-					
Channel 6	CO 300ppm	A1	✓				
		A2	✓		✓		
		A3	✓		✓	✓	
		-					

h) Standard configuration PEN08

Variation of PEN07: two zones with four detectors in Zone 1 and two detectors in Zone 2

<b>PEN08</b>			F	R1	R2	R3	R4	R5
		<b>FAULT</b>	✓					
<b>Channel #</b>	<b>Target gas &amp; range</b>	<b>Power Failure</b>	✓					
<b>Channel 1</b>	<b>CO 300ppm</b>	<b>A1</b>		✓				
		<b>A2</b>		✓	✓			
		<b>A3</b>		✓	✓	✓		
		<b>-</b>						
<b>Channel 2</b>	<b>CO 300ppm</b>	<b>A1</b>		✓				
		<b>A2</b>		✓	✓			
		<b>A3</b>		✓	✓	✓		
		<b>-</b>						
<b>Channel 3</b>	<b>CO 300ppm</b>	<b>A1</b>		✓				
		<b>A2</b>		✓	✓			
		<b>A3</b>		✓	✓	✓		
		<b>-</b>						
<b>Channel 4</b>	<b>CO 300ppm</b>	<b>A1</b>		✓				
		<b>A2</b>		✓	✓			
		<b>A3</b>		✓	✓	✓		
		<b>-</b>						
<b>Channel 5</b>	<b>CO 300ppm</b>	<b>A1</b>		✓				
		<b>A2</b>		✓			✓	
		<b>A3</b>		✓			✓	✓
		<b>-</b>						
<b>Channel 6</b>	<b>CO 300ppm</b>	<b>A1</b>		✓				
		<b>A2</b>		✓			✓	
		<b>A3</b>		✓			✓	✓
		<b>-</b>						

i) Standard configuration PEN09

Variation of PEN07: two zones with five detectors in Zone 1 and one detector in Zone 2

PEN09		F	R1	R2	R3	R4	R5	
		FAULT	✓					
Channel #	Target gas & range	Power Failure	✓					
Channel 1	CO 300ppm	A1		✓				
		A2		✓	✓			
		A3		✓	✓	✓		
		-						
Channel 2	CO 300ppm	A1		✓				
		A2		✓	✓			
		A3		✓	✓	✓		
		-						
Channel 3	CO 300ppm	A1		✓				
		A2		✓	✓			
		A3		✓	✓	✓		
		-						
Channel 4	CO 300ppm	A1		✓				
		A2		✓	✓			
		A3		✓	✓	✓		
		-						
Channel 5	CO 300ppm	A1		✓				
		A2		✓	✓			
		A3		✓	✓	✓		
		-						
Channel 6	CO 300ppm	A1		✓				
		A2		✓			✓	
		A3		✓			✓	✓
		-						

### 3.2.3 Standard Configurations for Laboratories

The U•V6 unit comprises several standard configurations for laboratory use. These configurations may be adapted, based on the needs of the installation.

a) Standard Configuration LAB01

- Six detectors in a single zone (see the diagram below);
- five independent relays:
  - The first two relays, Relays 1 & 2 (terminals 7 to 12 on the diagram) are addressed by level-one alarms
  - the last two relays, Relays 3 & 4 (terminals 13 to 18 on the diagram) are addressed by level-two alarms
  - the shared relay, Relay 5 (terminals 19 to 21 on the diagram) is addressed by level-two alarms in siren mode.
- The relays are configured in non-failsafe mode, i.e. they are not powered when idle, but are powered if an alarm is triggered;
- battery operation is disabled;
- the external alarm input is disabled.

**i** Please contact a **DALEMANS** representative for more details on custom standard basic configurations.

<b>LAB01</b>			F	R1	R2	R3	R4	R5
		<b>FAULT</b>	✓					
<b>Channel #</b>	<b>Target gas &amp; range</b>	<b>Power Failure</b>	✓					
<b>Channel 1</b>	<b>CO2 5000ppm</b>	<b>A1</b>		✓	✓			
		<b>A2</b>				✓	✓	<b>S</b>
		-						
		-						
<b>Channel 2</b>	<b>CO2 5000ppm</b>	<b>A1</b>		✓	✓			
		<b>A2</b>				✓	✓	<b>S</b>
		-						
		-						
<b>Channel 3</b>	<b>CO2 5000ppm</b>	<b>A1</b>		✓	✓			
		<b>A2</b>				✓	✓	<b>S</b>
		-						
		-						
<b>Channel 4</b>	<b>CO2 5000ppm</b>	<b>A1</b>		✓	✓			
		<b>A2</b>				✓	✓	<b>S</b>
		-						
		-						
<b>Channel 5</b>	<b>CO2 5000ppm</b>	<b>A1</b>		✓	✓			
		<b>A2</b>				✓	✓	<b>S</b>
		-						
		-						
<b>Channel 6</b>	<b>CO2 5000ppm</b>	<b>A1</b>		✓	✓			
		<b>A2</b>				✓	✓	<b>S</b>
		-						
		-						

b) Standard configuration LAB02

Standard Configuration LAB02 allows the user to monitor the presence of gas in two separate zones. Relay 5 is common to both zones and its addressed alarm conditions are in siren mode.

<b>LAB02</b>		F	R1	R2	R3	R4	R5
		FAULT	✓				
<b>Channel #</b>	<b>Target gas &amp; range</b>	Power Failure	✓				
<b>Channel 1</b>	<b>CO2 5000ppm</b>	A1		✓			
		A2			✓		<b>S</b>
		-					
		-					
<b>Channel 2</b>	<b>CO2 5000ppm</b>	A1		✓			
		A2			✓		<b>S</b>
		-					
		-					
<b>Channel 3</b>	<b>CO2 5000ppm</b>	A1		✓			
		A2			✓		<b>S</b>
		-					
		-					
<b>Channel 4</b>	<b>CO2 5000ppm</b>	A1			✓		
		A2				✓	<b>S</b>
		-					
		-					
<b>Channel 5</b>	<b>CO2 5000ppm</b>	A1			✓		
		A2				✓	<b>S</b>
		-					
		-					
<b>Channel 6</b>	<b>CO2 5000ppm</b>	A1			✓		
		A2				✓	<b>S</b>
		-					
		-					

c) Standard configuration LAB03

Standard Configuration LAB03 is intended to detect an excess or deficit of oxygen:

- A1 = 19% vol. (decreasing)
- A2 = 17% vol. (decreasing)
- A3 = 22% vol. (increasing)

Relays 3 and 5 are in siren mode.

<b>LAB03</b>		F	R1	R2	R3	R4	R5	
	<b>FAULT</b>	✓						
<b>Channel #</b>	<b>Target gas &amp; range</b>	<b>Power Failure</b>	✓					
<b>Channel 1</b>	<b>O2 25% vol.</b>	<b>A1</b>		✓				
		<b>A2</b>			✓	<b>S</b>		
		<b>A3</b>					✓	<b>S</b>
		-						
<b>Channel 2</b>	<b>O2 25% vol.</b>	<b>A1</b>		✓				
		<b>A2</b>			✓	<b>S</b>		
		<b>A3</b>					✓	<b>S</b>
		-						
<b>Channel 3</b>	<b>O2 25% vol.</b>	<b>A1</b>		✓				
		<b>A2</b>			✓	<b>S</b>		
		<b>A3</b>					✓	<b>S</b>
		-						
<b>Channel 4</b>	<b>O2 25% vol.</b>	<b>A1</b>		✓				
		<b>A2</b>			✓	<b>S</b>		
		<b>A3</b>					✓	<b>S</b>
		-						
<b>Channel 5</b>	<b>O2 25% vol.</b>	<b>A1</b>		✓				
		<b>A2</b>			✓	<b>S</b>		
		<b>A3</b>					✓	<b>S</b>
		-						
<b>Channel 6</b>	<b>O2 25% vol.</b>	<b>A1</b>		✓				
		<b>A2</b>			✓	<b>S</b>		
		<b>A3</b>					✓	<b>S</b>
		-						

d) Standard configuration LAB04

Standard Configuration LAB04 is intended for mixed use, i.e. detection of toxic gases + detection of an excess or deficit of oxygen.

<b>LAB04</b>			F	R1	R2	R3	R4	R5	
		<b>FAULT</b>	✓						
<b>Channel #</b>	<b>Target gas &amp; range</b>	<b>Power Failure</b>	✓						
<b>Channel 1</b>	<b>O2 25% vol.</b>	<b>A1</b>		✓	✓				
		<b>A2</b>				✓	<b>S</b>		
		<b>A3</b>							✓
		<b>-</b>							
<b>Channel 2</b>	<b>O2 25% vol.</b>	<b>A1</b>		✓	✓				
		<b>A2</b>				✓	<b>S</b>		
		<b>A3</b>							✓
		<b>-</b>							
<b>Channel 3</b>	<b>O2 25% vol.</b>	<b>A1</b>		✓	✓				
		<b>A2</b>				✓	<b>S</b>		
		<b>A3</b>							✓
		<b>-</b>							
<b>Channel 4</b>	<b>CO2 5000ppm</b>	<b>A1</b>		✓	✓				
		<b>A2</b>				✓	<b>S</b>		
		<b>-</b>							
		<b>-</b>							
<b>Channel 5</b>	<b>CO2 5000ppm</b>	<b>A1</b>		✓	✓				
		<b>A2</b>				✓	<b>S</b>		
		<b>-</b>							
		<b>-</b>							
<b>Channel 6</b>	<b>CO2 5000ppm</b>	<b>A1</b>		✓	✓				
		<b>A2</b>				✓	<b>S</b>		
		<b>-</b>							
		<b>-</b>							



### e) Standard configuration LAB05

Standard Configuration LAB05 is intended for mixed use, i.e. detection of toxic + inflammable gases + monitoring of the oxygen levels in two zones.

LAB05			F	R1	R2	R3	R4	R5
		FAULT	✓					
Channel #	Target gas & range	Power Failure	✓					
Channel 1	O2 25% vol.	A1		✓	✓			
		A2			✓			S
		A3						S
		-						
Channel 2	CO2 5000ppm	A1		✓				
		A2			✓			S
		-						
		-						
Channel 3	Inflammable 100% LEL	A1		✓				
		A2			✓			S
		-						
		-						
Channel 4	O2 25% vol.	A1				✓		
		A2					✓	S
		A3					✓	S
		-						
Channel 5	CO2 5000ppm	A1				✓		
		A2					✓	S
		-						
		-						
Channel 6	Inflammable 100% LEL	A1				✓		
		A2					✓	S
		-						
		-						

## 3.3 Target Gases and Alarm Thresholds

Each configuration of the U•V6 unit comprises preset alarm thresholds for each target gas. These are saved in the unit's memory and may be assigned to each input channel.

The settings associated with a given target gas are as follows:

- **Target Gas name:** the name of the molecule or gaseous compound to be detected. The target gas selected for an input channel must correspond to the target gas for the connected detector
- **Range of Measurement:** in the event that gas is detected, this value corresponds to the full-scale measurement, i.e. the highest gas concentration that can be measured. The range of measurement selected on a channel must match the range of measurement for the connected detector
- **Unit of Measurement:** the physical value that characterises the signal measured
- **Number of Alarm Thresholds:** allows the user to define several alarm conditions with different threshold values or calculation methods

All the settings for a target gas that are used on one or more input channels apply to all of these input channels.

### 3.3.1 Target gases for car parks

The following table lists the preset target gases for car parks:

TARGET GASES & ALARM LEVELS – CAR PARKS										
Target gas	Range	Alarm Level 1 (A1)			Alarm Level 2 (A2)			Alarm Level 3 (A3)		
		Threshold	Type	Latching mode	Threshold	Type	Latching mode	Threshold	Type	Latching mode
CO	300ppm	30 ppm	TWA** 15 min	Non-latching	60ppm	TWA** 15 min	Non-latching	150 ppm	1 min above threshold	Latching
NO <sub>2</sub>	30ppm	3 ppm	TWA** 15 min	Non-latching	6ppm	TWA** 15 min	Non-latching	15 ppm	1 min above threshold	Latching
LPG	100% LEL	10% LEL	Instantané	Latching	20% LEL	Instant	Latching	40% LEL	Instant	Latching
CNG	100% LEL	10% LEL	Instantané	Latching	20% LEL	Instant	Latching	40% LEL	Instant	Latching

\* Alarm Levels: A1 is the alarm level 1, A2 is the alarm level 2, A3 is the alarm level 3.

#### Types of Alarm:

- **Instant:** the alarm triggers the moment the measurement from the detector exceeds the threshold value.
- **TWA 15 min:** *Time Weighted Average* of 15 min. The value that is compared with the alarm threshold takes into account the sum of the last 15 minutes of measurements, which is divided by the period monitored.
- **1 min above threshold:** the value measured must be over the threshold for a full minute in order to trigger the alarm condition. This detection method is recommended by standard EN 50545-1 and ensures rapid action whilst avoiding false positives.

The reference gas for all the standard car park configurations (PENxx and PLExx) is CO with a range of 300 ppm, but the user can select a different target gas for each channel in order to connect a different detector, to detect nitrogen dioxide (NO<sub>2</sub>), for example.

**i** The PENxx standard configurations have been designed in accordance with EN 50545-1. However, any subsequent modification may impact compliance with this standard. Please contact your **DALEMANS sa/nv** representative for more information.

**i** It is also possible to optionally select other configurations for the U•V6 unit. Please contact your **DALEMANS sa/nv** representative for more information.

### 3.3.2 Target Gases for Laboratories

The target gases encountered in laboratories are numerous and diverse. The table below includes the information that is pre-saved in the unit:

TARGET GASES & ALARMS - LABORATORIES										
Tgt gas	Range	Alarm level 1 (A1)			Alarm level 2 (A2)			Alarm level 3 (A3)		
		Thresh old	Type	Latching mode	Threshold	Type	Latching mode	Thres hold	Type	Latching mode
CO	300 ppm	20 ppm	Instant	Non-latching	50 ppm	Instant	Latching	-	-	-
CO	500 ppm	100 ppm	Instant	Non-latching	150 ppm	Instant	Latching	-	-	-
CO	1000 ppm	100 ppm	Instant	Non-latching	150 ppm	Instant	Latching	-	-	-
NO <sub>2</sub>	30 ppm	3 ppm	Instant	Non-latching	5 ppm	Instant	Latching	-	-	-
CO <sub>2</sub>	5000 ppm	800 ppm	Instant	Non-latching	2000 ppm	Instant	Latching	-	-	-
CO <sub>2</sub>	4% vol.	1% vol.	Instant	Non-latching	2% vol.	Instant	Latching	-	-	-
O <sub>2</sub>	25% vol.	19% vol.	Instant falling	Non-latching	17% vol.	Instant falling	Latching	22% vol.	Instant rising	Latching
NH <sub>3</sub>	100 ppm	20 ppm	Instant	Non-latching	50 ppm	Instant	Latching	-	-	-
NH <sub>3</sub>	1000ppm	50 ppm	Instant	Non-latching	200 ppm	Instant	Latching	-	-	-
NH <sub>3</sub>	5000ppm	1000 ppm	Instant	Non-latching	2000 ppm	Instant	Latching	-	-	-
H <sub>2</sub> S	50ppm	5 ppm	Instant	Non-latching	20 ppm	Instant	Latching	-	-	-
H <sub>2</sub> S	100ppm	10 ppm	Instant	Non-latching	40 ppm	Instant	Latching	-	-	-
H <sub>2</sub> S	300ppm	30 ppm	Instant	Non-latching	120 ppm	Instant	Latching	-	-	-
SO <sub>2</sub>	20ppm	2 ppm	Instant	Non-latching	5 ppm	Instant	Latching	-	-	-
Cl <sub>2</sub>	10ppm	2 ppm	Instant	Non-latching	4 ppm	Instant	Latching	-	-	-
O <sub>3</sub>	1ppm	0.25 ppm	Instant	Non-latching	0.5 ppm	Instant	Latching	-	-	-
Flam mabl e**	100% LEL	20% LEL	Instant	Non-latching	40% LEL	Instant	Latching	-	-	-
pH	14	10	Instant	Non-latching	10.5	Instant	Latching	-	-	-

\* Alarm Levels: A1 is the alarm level 1, A2 is the alarm level 2, A3 is the alarm level 3.

\*\* « Flammable » is a generic name that allows to target various flammable gases (e.g. : methane, propane, butane, hydrogen, ...)

The ranges of measurement that are not included on this list are not compatible with the control unit.

The U•V6 unit is also able to apply alarms associated with the **Occupational Exposure Limits** (OEL) from the publications of the official journal of the European Commission for most of the gases listed in the present document. There are usually two threshold values per gas:

- **STEL** (*Short-Term Exposure Limit*): the threshold is based on a time-weighted average of 15 minutes.
- **LTEL** (*Long-Term Exposure Limit*): the threshold is based on a time-weighted average of 8 hours.

---

 Please contact **DALEMANS sa/nv** for more information.

---

# 4 USER MENUS

---

The user can access the menus presented in this section, since they do not require any special access privileges.

## 4.1 Main menu

The user can access the main menu by simply pressing **ENTER**:

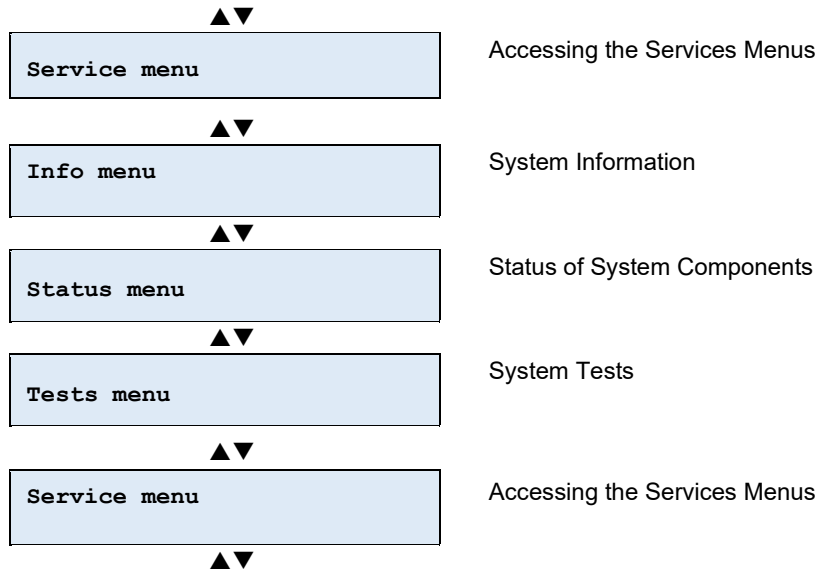

The user can navigate the menus using the arrow keys on the keyboard and then make a selection by pressing **ENTER**.

## 4.2 Info Menu

The *Info menu* provides information about all the components of the U•V6 unit.

All these items can only be accessed in read-only mode, except for the date.

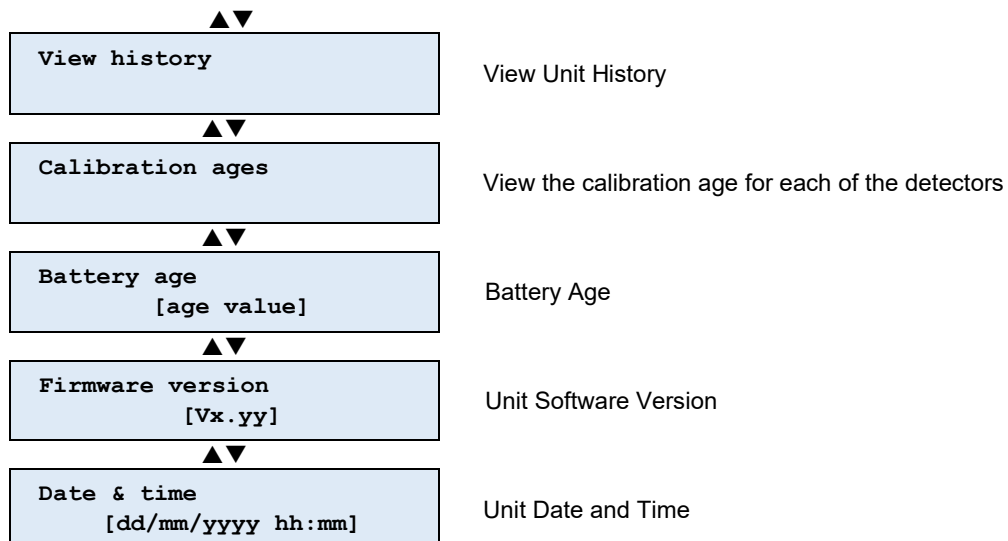

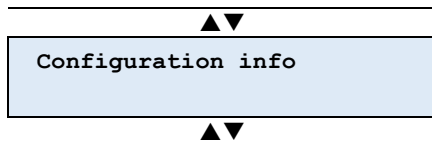

Submenu providing the configuration information for the U•V6 unit

- 
- ① Navigation through the menus is done using the directional keys on the keyboard and selection using the **ENTER** key.
- 

## 4.2.1 History

*View History* allows the user to view the events that have been logged by the unit. These are given in chronological order.

## 4.2.2 Calibration Age

The *Calibration Age* menu allows the user to view the time that has passed since the detectors were last calibrated. This allows the unit to generate a maintenance alert once the maintenance interval has been exceeded (see **Paragraph 5.2 Advanced System Tests**)

## 4.2.3 Battery Age

*Battery Age* on the *Info Menu* allows the user to view the age of the battery in number of days.

## 4.2.4 Firmware Version

*Firmware Version* on the *Info Menu* allows the user to view the version number of the firmware (the operating system for the unit).

## 4.2.5 Date and Time

The date and time of the U•V6 unit are stored in Non-Volatile memory. They are only updated when the unit is powered.

If the date or time of the U•V6 unit is incorrect, the user can press **ENTER** on the keyboard to enter edit mode.

- *Edit Date & Time* appears
- The cursor flashes on the value to be modified in the date or time field:

```
Date & time setting
dd/mm/yyyy hh:mm
```

The user can change the field to be modified using the **Right** and **Left** arrow keys:

The user can change the value in the selected field using the **Up** and **Down** arrow keys.

Once the date and time has been updated, the user can confirm the modification by pressing **ENTER**.

The user can cancel the modification and return to the info menu by pressing **ESC**.

## 4.3 Configuration Information

All the configuration items for the U•V6 unit can be consulted using the *Configuration Info* sub-menu, i.e.:

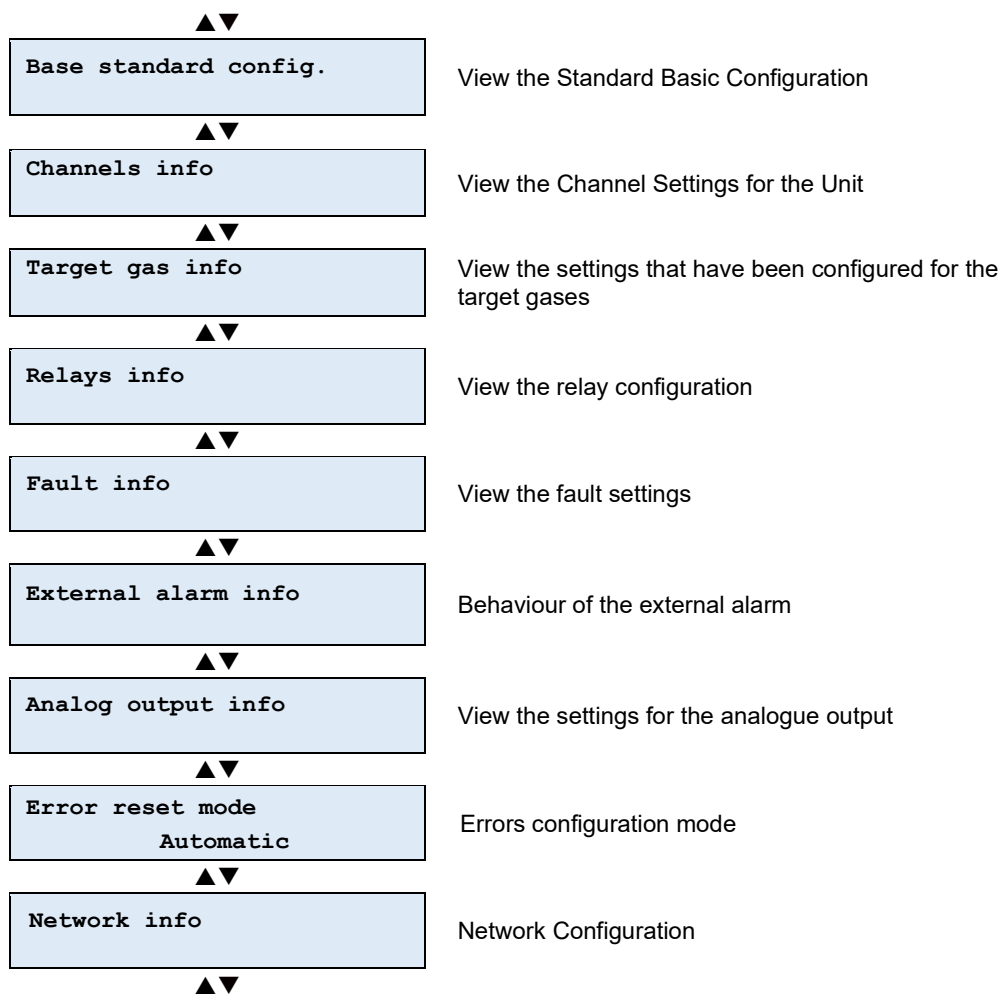

The user can navigate the menus using the arrow keys on the keyboard and then make their selection by pressing **ENTER**.

### 4.3.1 Base standard configuration

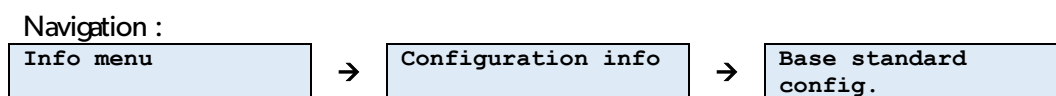

This is the base standard configuration, based on which the device was configured. The U•V6 is a device that allows a wide range of configurations.

Modifications to the configuration can be made following this selection.

---

**i** Please contact a **DALEMANS sa/nv** representative for more details about custom configurations.

---

## 4.3.2 Measurement Channels

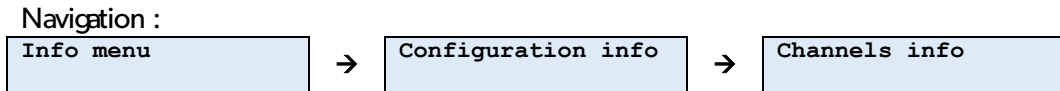

This sub-menu allows the user to view the specific configurations for each channel.

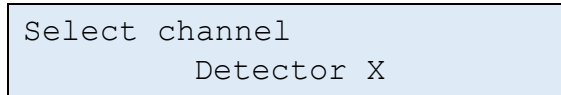

### a) Alarm Level Settings by Channel

The information for the different alarm levels associated with the type of gas configured in the unit for each channel can also be consulted via the *Alarm Level Settings* sub-menu

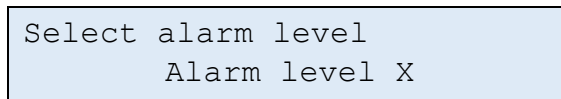

The **Up** and **Down** arrow keys allow the user to view the type of alarms configured in the U•V6 unit. When the user makes a selection using the **ENTER** key, the user can view the different configurations in the U•V6 unit by alarm level.

The items in the *Alarm Level Settings* sub-menu on the U•V6 unit allow the user to view the settings for the following:

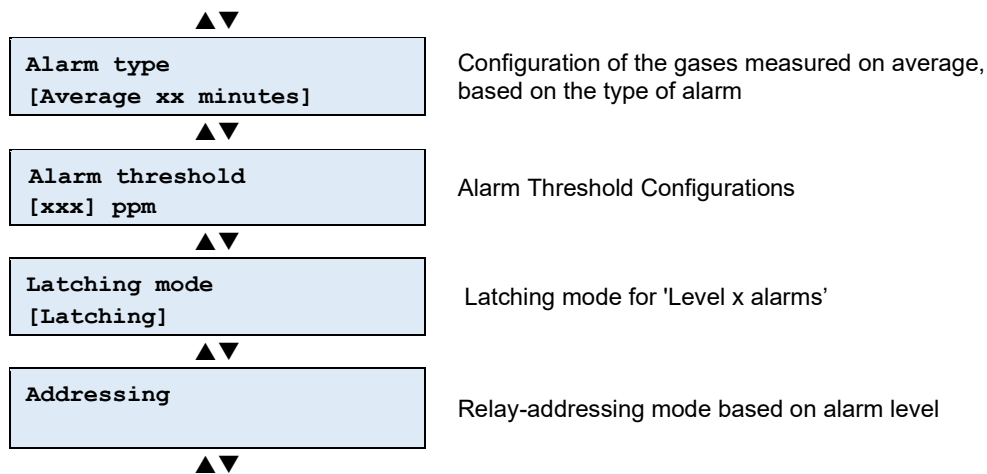

---

**i** The *Alarm Threshold*, *Latching Mode* and *Addressing* sub-menus are only visible if the alarm level has been activated.

---

### b) Alarm Type

*Alarm Type* allows the user to view the way in which the alarm is calculated:

- **Disabled**: this alarm level is deactivated
- **Instant**: this alarm level is based on the measurement at time t



- **Average:** this alarm level is calculated based on an average over time (configurable). It is triggered when the calculated value exceeds the configured threshold.
- **Above for xx minutes:** this alarm level is only triggered if the threshold is exceeded for at least xx minutes.

#### c) Alarm Thresholds

*Alarm Threshold* allows the user to view the value of the gas-concentration threshold for the selected alarm level.

```
Alarm threshold
      [xxxx PPM]
```

#### d) Latching Mode

*Latching Mode* allows the user to view the latching mode for the selected alarm level:

- **Latching:** when the cause of the alarm is gone, the alarm remains active until manual action is taken on the U•V6 unit (**RESET button pressed twice**).
- **Non-latching:** when the cause of the alarm is gone, the alarm is automatically reset and disappears.

---

**i** The U•V6 unit might display an alarm message when the gas concentration has already fallen below the alarm threshold, when the unit alarms are latched. An alarm based on an average over time may remain active when the measurement time  $t$  is below the threshold. It is normal for it not to be possible to reset the alarm in such a scenario. It will only be possible to reset the alarm when the average value falls below the configured threshold.

---

#### e) Relay Addressing by Input Channel

The user can use this menu to see the relay(s) that will be activated for each alarm level and for each input channel in the event that the alarm condition is met.

```
Alarm type
      Addressed / not Addressed
```

The following configurations are possible on the channel X, alarm level Y and relay Z menu:

- **Unaddressed:** the selected relay, Z, will not be activated based on the selected alarm, Y, for the selected channel, X.
- **Addressed:** the selected relay, Z, will be activated when the alarm condition, Y, for channel X is met.
- **Siren Mode:** the selected relay, Z, will act like an output siren: the relay will be triggered when there is an alarm, but it will be possible to disarm it by pressing **MUTE/RESET** on the keyboard.

**i** The user can only view the configuration. Any modifications must be carried out by a technician certified by **DALEMANS sa/nv**.

### 4.3.3 Target Gases

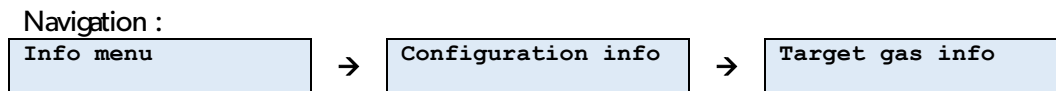

The U•V6 unit has a logic that is closely associated with the concept of “target gas”. A target gas can be linked with each input channel and the alarm levels are linked with each target gas. This logic allows the user to configure the control unit easily and systematically.

The items on this U•V6 unit sub-menu allow the user to see the different settings that are specific to each target gas targeted by one or more channels of the unit.

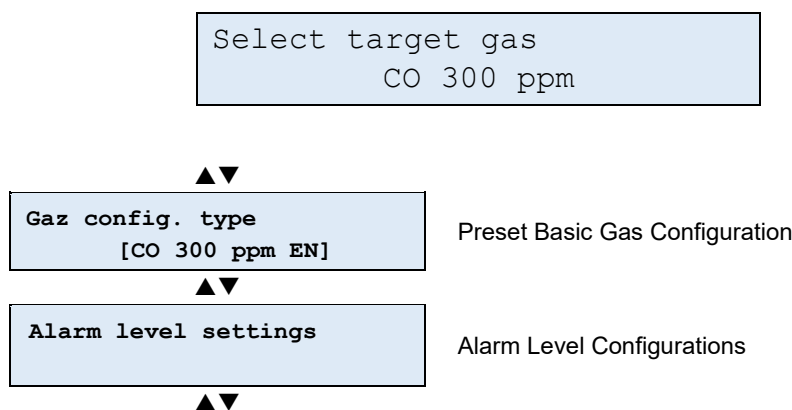

#### a) Gas Config Type

*Gas config. type* allows the user to view the standard used for the selected target gas. There are several of these:

- **Car park:** the alarm levels (thresholds and calculation methods) are those outlined in standard EN 50545-1
- **Legacy:** corresponds to the previous alarm levels recommended by Dalemans prior to the publication of standard EN 50545-1
- **Lab:** alarm levels recommended by Dalemans for laboratories. This usually comprises two alarm levels based on the measurement at time *t*.
- **EU OEL:** *stricto sensu* the **Occupational Exposure Limits (OEL)**, as described by the European Commission. This usually comprises one alarm level that is calculated as an average over a period of 15 minutes and a second alarm level that is calculated as an average over 8 hours.

#### b) Alarm Level Settings

The information for the different alarm levels associated with the type of gas configured in the unit can be accessed from the *Alarm Level Settings* sub-menu.

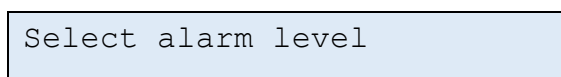

Alarm level X

The following information is configured for each alarm level:

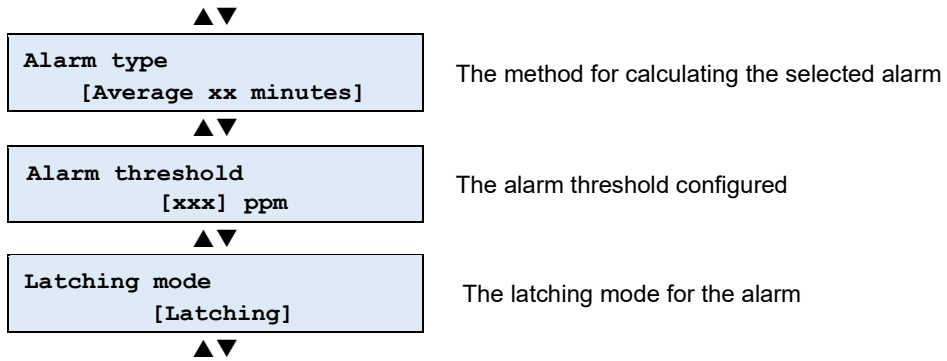



---

**i** The *Alarm Threshold* and *Latching Mode* sub-menus are only visible if the corresponding alarm level has been enabled.

---

All the items in this menu are explained at paragraph § 3.3 Target Gases and Alarm Thresholds.

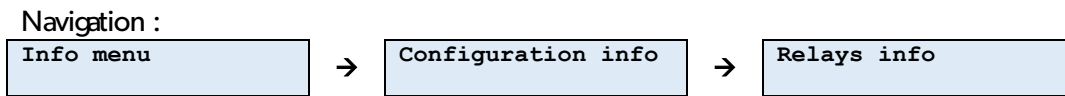
### 4.3.4 Relay Configuration



The *Relay Info* sub-menu allows the user to view the configuration for each relay, i.e. the failsafe mode and addressing for it.

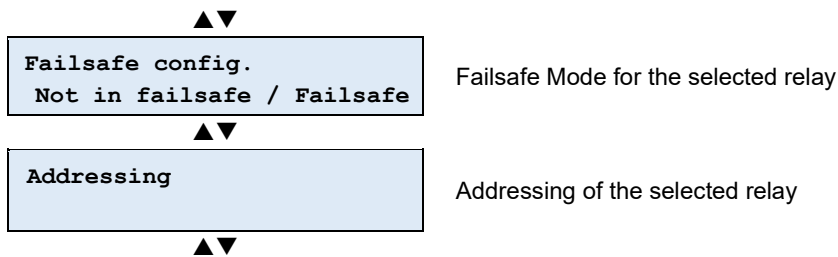

#### a) Relay Failsafe Mode

The failsafe mode of a relay defines its status when it is idle:

- **Non-failsafe:** the relay is not powered when it is idle.
- **Failsafe:** the relay is powered when it is idle.

- 
- i** By default, all the relays are failsafe: OFF, except for the fault relay, which is always failsafe: ON.
- 

## b) Addressing

*Addressing* allows the user to view the addressing for the selected relay. Addressing is the set of conditions that activate a relay.

These conditions may be as follows:

- One or more alarm levels coming from one or more input channels
- Activation of the external alarm input
- *Power Failure*
- *Fault*

```
Detector x
Ax - Normal mode / Siren mode
```

There are two ways for the user to act on a relay:

- **Normal mode:** the relay cannot be reset as long as the triggering condition is still active.
- **Siren mode:** comprises specific behaviour similar to that of the U•V6 unit's siren output or its buzzer, i.e. the relay can be reset when the triggering condition is still active.

If a relay is **not addressed by any**:

- *Detector*
- *External Alarm*
- *Power Failure*
- *Fault*

```
Alarm relay x
Not addressed at all
```

- 
- i** Any enabling or disabling of settings should be carried out by a technician certified by **DALEMANS sa/nv**.
- 

## 4.3.5 Fault Menu

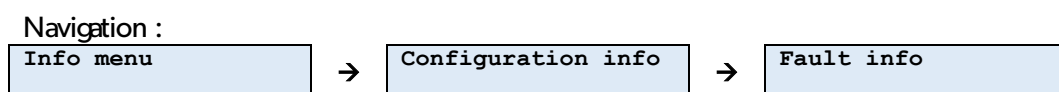

The U•V6 unit has internal fault management – *Fault Menu*. If any unusual use of the U•V6 unit or a detector is detected, the system sends a notification via action on a relay that signals the technical fault, and the **Fault** LED lights up.

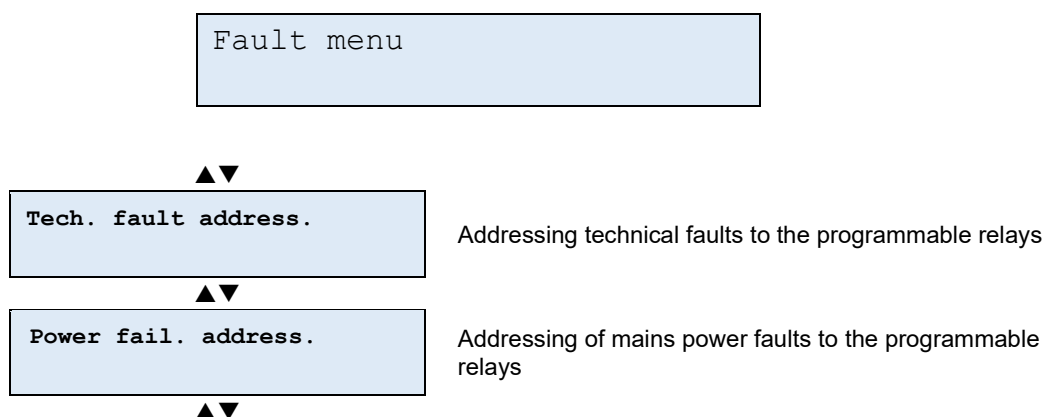

### a) Technical-Fault Addressing

The *Tech. Fault Address.* sub-menu allows the user to address each relay respectively and specifically in the event that a technical fault is detected.

The following configurations are possible:

- **Unaddressed:** the selected programmable relay will not be activated by a technical fault.
- **Addressed:** the selected relay will switch when a technical fault is detected.
- **Siren Mode:** the selected relay, Z, will act like an output siren: the relay will be triggered when there is an alarm, but it will be possible to disarm it by pressing **MUTE/RESET** on the keyboard.

```

Alarm relay x
  Not addressed / addressed
  
```

---

**i** Any enabling or disabling of settings should be carried out by a technician certified by **DALEMANS sa/nv**.

---

The U•V6 unit also has a dedicated output for connecting a DC-powered siren. It is possible to associate the activation of this output with the detection of a technical fault using the following setting:

```

Siren output
  Not addressed / addressed
  
```

### b) Power-Failure Addressing

A Power Failure is activated when the power from the network is missing and the unit switches to its battery.

Its addressing to the programmable relays is configured in the same way as technical-fault addressing.

### 4.3.6 External Alarm Menu

Navigation :

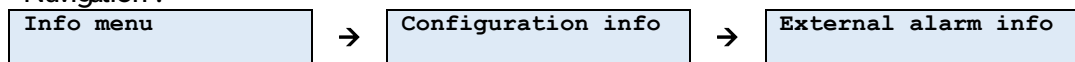

The *External Alarm Menu* sub-menu allows the user to view the settings associated with the external alarm input, i.e. its behaviour and the actions that are triggered when it switches.

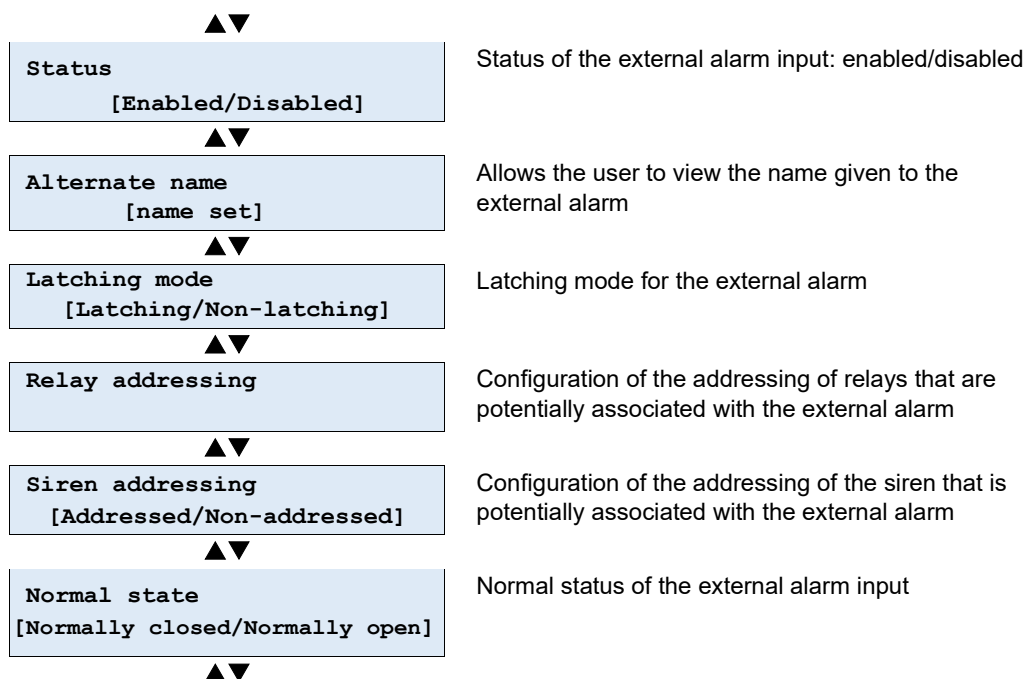

#### a) Status of the External Alarm

The external alarm can have the following statuses:

- **Disabled:** a status change on the input will not have any effect
- **Enabled:** a status change on the alarm input is triggered, based on the type of mode configured on the U•V6 unit

#### b) Alternate name

Alternate name allows to give a specific name to the external alarm, so that it can be displayed on the screen in the event of an alarm is triggered.

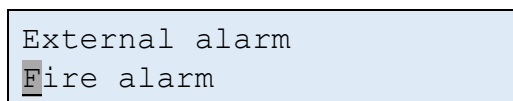

The cursor flashes on the character being edited.

### c) Latching Mode

*Latching mode* allows the user to configure the latching mode for the external alarm:

- **Latching:** when the cause of the alarm is gone, the alarm remains active until manual action is taken on the unit (**RESET button pressed twice**).
- **Non-latching:** when the cause of the alarm is gone, the alarm is automatically reset and disappears.

### d) Relay Addressing Mode from the External Alarm

*Ext. Alarm Addressing* allows the user to specifically address each relay, based on the activation of the external alarm:

Alarm relay x Not addressed / addressed
--

The **Up** and **Down** arrow keys allow the user to view the respective type of configuration mode for the external alarm in the U•V6 unit for each relay.

The way the U•V6 unit reacts to a change in status on the external alarm can be configured.

The following configurations are possible:

- **Not addressed:** the selected relay will not be activated by the external alarm input.
- **Addressed:** the selected relay switches when a change in the status of the external alarm input occurs.
- **Siren Mode:** the selected relay, Z, will act like an output siren: the relay will be triggered when there is an alarm, but it will be possible to disarm it by pressing **MUTE/RESET** on the keyboard.

---

**i** Any enabling or disabling of settings should be carried out by a technician certified by **DALEMANS sa/nv**.

---

### e) Siren Addressing Mode from the External Alarm

*Siren Addressing* allows the user to define how the siren behaves when the external alarm is triggered.

The following statuses are possible:

- **Addressed:** the buzzer and the output siren of the unit are activated when the external alarm is activated.
- **Not addressed:** the buzzer and the output siren of the unit are not associated with the status of the external alarm input.

---

**i** By default, the external alarm is addressed to the siren output of the unit.

**i** Unaddressed Siren mode is useful when the actions taken on the relays has to depend on what is connected to the external alarm input, without this being interpreted as a gas alarm (e.g. a fire-detection system).

---

#### f) Normal Status of the External Alarm

The external alarm, when enabled, is triggered by a change in status of its dedicated input on the U•V6 unit. This configuration item specifies the status of the input when idle and, as a result, the nature of the change in status that triggers the alarm.

The following statuses are possible:

- **Normally Closed:** the circuit connected to the input is closed when idle. Therefore, the external alarm is activated when the circuit opens.
- **Normally Open:** the circuit connected to the input is open when idle. Therefore, the external alarm is activated when the circuit closes.

### 4.3.7 Analogue Output

The U•V6 unit has an analogue output that allows the user to output a signal that is proportional to the maximum value of the measurements taken at time  $t$  for one or more detectors that are connected to the unit.

By default, the six input channels are integrated into the calculation of the maximum value. If only one channel is integrated into the calculation, the analogue output acts directly on the measurement taken at time  $t$  for this channel.

The user can choose one of the following for this output signal:

- A **4-20 mA** industrial current loop
- A **0-20mA** current loop
- Or a **0-10V** electrical voltage

The user can switch the analogue output from current mode to voltage mode by using the switch on the motherboard of the U•V6 unit.

Furthermore, it is possible to select a split ratio for this measurement, in order to adapt the output signal to the various devices.

By default, the analogue output is configured as follows:

- The signal is proportional to the **maximum measurement for the six input channels**
- The output mode is configured as a **4-20mA** current loop.
- The gain ratio is configured as **1:1**

For details of the possible configurations, please see **Paragraph 2.7 Connecting the Analogue Output**.

The *Analogue Output Info* sub-menu allows the user to view the settings for the analogue output of the U•V6 unit.

When the user makes a selection using the **ENTER** key, they can view the settings for the analogue output in the U•V6 unit.

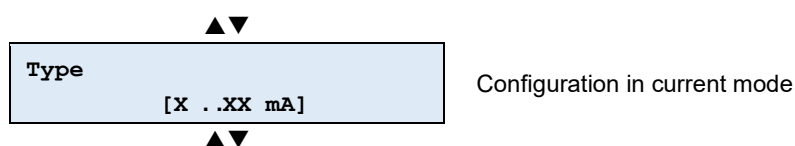



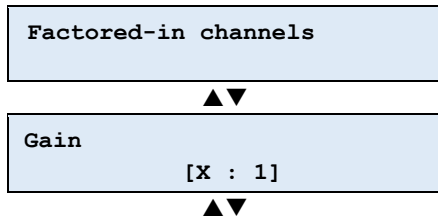

Gain detector status configuration. Only visible if the analogue output has been enabled

Gain configuration. Only visible if the analogue output has been enabled

The **Up** and **Down** arrow keys allow the user to view the gain type that has been configured in the U•V6 unit for each detector.

#### a) Current-Mode Configuration

Current Mode includes three settings, with the following possible configurations:

- **Disabled**: the circuit connected to the analogue output is not active
- **0-20mA** current loop
- **4-20mA** current loop

#### b) Channels Factored into the Calculation of the Output Signal

The **Factored-In Channels** sub-menu allows the user to select the measurement channels that are taken into consideration when calculating the analogue output signal.

The calculation in question is a **maximum value** from among the channels measurements that are taken into account.

When the user makes a selection using the **ENTER** key, they can view the gain status of the detector, whether it is enabled or disabled, in the U•V6 unit.

The user can use the **Up** and **Down** arrow keys to view the list of detectors, along with their respective statuses, in the U•V6 unit.

```
1. Detector x
   Factored in / Disabled
```

This sub-menu is only visible if the analogue output has been enabled.

#### c) Output Gain

The **Gain** sub-menu allows the user to view the additional gain ratio for the analogue output. By default, it is set to 1 (no effect).

```
Gain
      X : 1
```

The different possible gain-ratio settings are as follows: 1:1, 2:1, 3:1, 5:1, 10:1

---

**i** Any enabling or disabling of settings should be carried out by a technician certified by **DALEMANS sa/nv**.

---

### 4.3.8 Errors reset mode

The U•V6 Control Unit has an internal fault management. Once detected, any abnormal operation of the U•V6 Control Unit or detector is notified by an action on the relay signaling the technical defect.

The mode to reset a technical fault specifies how it is reset:

- **Automatic** reset:

```
Error reset mode
Automatic
```

When the cause of the error restored, the message is automatically reset and disappears.

- **Manual** reset:

```
Error reset mode
Manual acknowledge
```

When the cause of the error disappears, the message remains visible until the user manually acknowledges it by pressing **twice** on the **MUTE/RESET** button.

- 
- ① All U•V6 centrals for underground car parks are configured for manual reset ex works.
  - ① All U•V6 control units for **laboratory** applications are configured for **automatic** reset from the factory.
  - ① Changing the error reset mode should be carried out by a technician certified by **DALEMANS**.
- 

### 4.3.9 Network Info

*Network Info* is only available if the Ethernet interface has been enabled. This allows the user to view the following:

- The IP address of the U•V6
- The IP address of the network gateway

Those parameters allow to establish a connection with the U•V6 control unit using **MODBUS TCP**.

- 
- ① More more information on the configuration and usage of the interface, please refer to **U•Line Modbus Interface Manual** document.
-

## 4.4 Statuses Menu

The *Statuses Menu* allows the user to view the status of the components of the U•V6 unit.

	Sub-menu	Contents
▲▼		
<div style="border: 1px solid black; padding: 5px; width: fit-content; margin: 0 auto;">Measurement channels</div>	Measurement Channels	<p>Provides the statuses for each channel:</p> <ul style="list-style-type: none"> <li>- <b>Disabled:</b> the system considers this channel to be inactive</li> <li>- Measurement Display</li> </ul>
▲▼		
<div style="border: 1px solid black; padding: 5px; width: fit-content; margin: 0 auto;">Outputs</div>	Outputs	<p>Provides the status of the outputs:</p> <ul style="list-style-type: none"> <li>- The system considers this output to be disabled</li> <li>- <b>enabled/disabled</b></li> </ul>
▲▼		
<div style="border: 1px solid black; padding: 5px; width: fit-content; margin: 0 auto;">Analog Output</div>	Analogue Output	<p>Gives the status of the analogue output:</p> <ul style="list-style-type: none"> <li>- The system considers the analogue output to be disabled</li> <li>- 0-20mA: if the user presses <b>ENTER</b>, the system gives the output current in mA</li> <li>- 4-20mA: if the user presses <b>ENTER</b>, the system gives the control output current in mA</li> </ul>
▲▼		
<div style="border: 1px solid black; padding: 5px; width: fit-content; margin: 0 auto;">Power supply [Value]</div>	Power Supply	<p>Indicates the status of the unit, i.e. connected to the mains or battery use, where applicable. The voltage of the unit is displayed when the user presses <b>ENTER</b>.</p>
▲▼		
<div style="border: 1px solid black; padding: 5px; width: fit-content; margin: 0 auto;">Battery [value]</div>	Battery	<p>States whether or not a battery is present. If a battery is present, the voltage of the battery is displayed when the user presses <b>ENTER</b>.</p>
▲▼		
<div style="border: 1px solid black; padding: 5px; width: fit-content; margin: 0 auto;">Temperature [xx °C]</div>	Temperature	<p>Indicates the temperature of the U•V6 unit: pressing <b>ENTER</b> causes the system to display the minimum, average and maximum temperatures.</p>
▲▼		

## 4.5 Test Menu

This *Test Menu* allows the user to check that the display or the LEDs on the front panel are working correctly. Gas detection works as per usual while a test is being carried out.

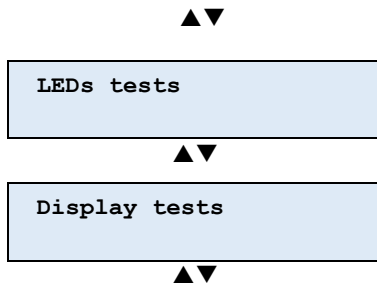

Sub-menu	Contents
LEDs tests	Run a test sequence that makes the LEDs blink one after another
Display tests	Run a test sequence that displays a character on each character position successively, while changing the display's backlight

# 5 SERVICE MENU

Service menus allow to modify the settings of the U•V6 unit that do require any knowledge regarding gas detection, or which cannot cause a gas-detection-related risk in the event of a fault or omission.

Please contact a technician certified by **DALEMANS** for a more in-depth analysis of your individual situation.

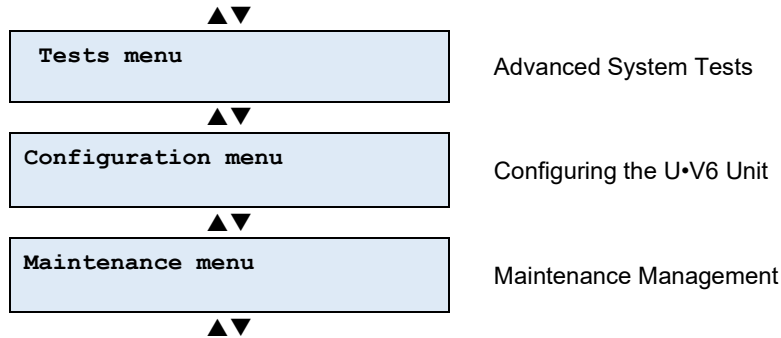

## 5.1 Protected Access

The Service Menu is protected by the following password:

**Code d'accès : 110**

**⚠** Do not use this password without reading the information contained in this manual. The functions on the Service Menu may affect the configuration of the unit!

When the user enters the Service Menu, the display enters into password-entry mode:

ENTER password

The **Up** and **Down** arrow keys allow the user to change the value of the character selected. The **Right** arrow key allows the user to move to the next character and the **Left** arrow key allows them to return to the previous character.

When the user moves from one character to another, the character that is no longer selected is hidden. This means that only the character being entered is visible.

ENTER password  
\* \* 0

The user can confirm the password they have entered by pressing **ENTER**. If it has been entered correctly, the Services Menu is activated and the **Tests Menu** sub-menu is displayed.

If the password entered is incorrect, the main menu remains active and the **Service Menu** is displayed again.

## 5.2 Advanced System Tests

- ❗ For details of the LED output tests '**LEDs tests**' and the '**Display tests**', for details refer to § 4.5 **Test menu**.

### 5.2.1 Outputs Tests



This item on the *Test Menu* allows the user to temporarily force the outputs to activate, in order to verify that they are working correctly (relays and siren).

- ⚠ Testing an output of the U•V6 unit means that it is activated, along with the servos that are connected to it (a gas valve or siren, etc.).

- ❗ This test does not allow the user to disable an output that has already been enabled.

Once the output test option has been selected, the user must select the output to be tested using the **Up** and **Down** arrow keys.

The status of the selected output is displayed each time.

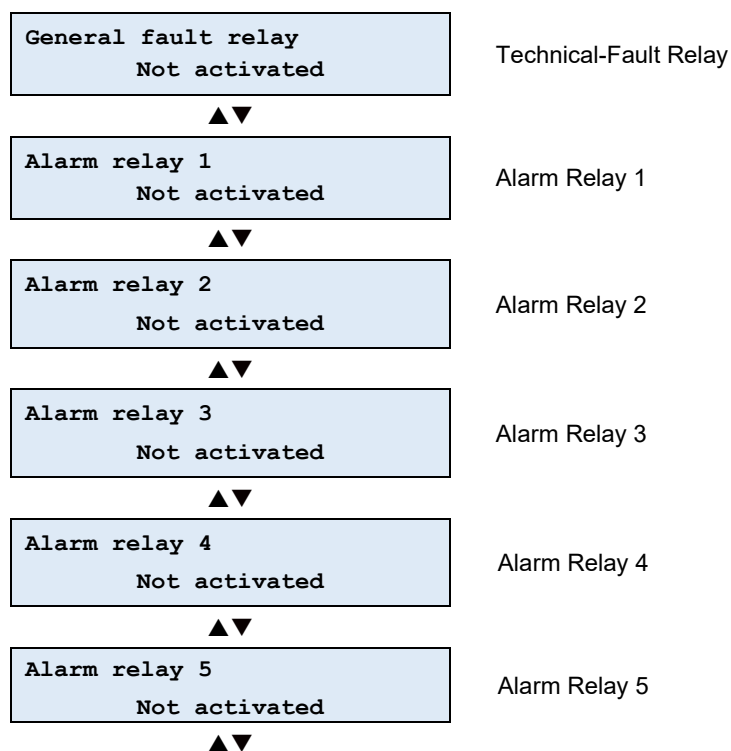

Siren output  
Not activated

Transistorised output for the siren

The user can confirm their selection by pressing **ENTER**. The system then asks for confirmation before switching the output.

General fault relay  
Ready to activate?

The user can confirm the activation of the selected output by pressing **ENTER**. It is then activated, along with the equipment that is connected to it.

General fault relay  
Activated

The output remains activated for the duration of the output test.

This comes to an end:

- upon manual action by user (pressing the **ESC** key).
- when the maximum activation time for the output (15 minutes) has expired.

The user may interrupt and cancel the **Output Test** function at any time by pressing **ESC** key. The tests sub-menu is then re-enabled and displays the output test function.

## 5.2.2 Analogue Output Test



This test allows the user to arbitrarily set a signal set point for the analogue output of the device. This allows the user, for example, to verify the connections and ensure that the receiver connected to this output is compatible with the unit.

The user can modify the simulated set point value using the **Up** and **Down** arrow keys.

The user can move from one digit to the next using the **Right** and **Left** arrow keys.

The user can end the simulation by pressing **ESC**.

- 
- i** The signal that is actually produced at the device output depends on the interface configuration chosen (0-20mA, 4-20mA, or 0-10 V). See Paragraph **4.3.7 Analogue Output**
- 

## 5.2.3 Simulating a Detector

Navigation :



A gas-detection simulation can be carried out without disconnecting a detector that is connected to a measurement channel on the U•V6 unit.

Once the function has been selected, the user must select the detector for which the simulation should be carried out.

The simulation starts when the detector has been selected:

- The initial value for the simulation is the actual gas concentration read by the detector.
- The cursor flashes on the digit being modified (tens or units).

The user can modify the simulated gas-concentration value using the **Up** and **Down** arrow keys.

The user can use the **Right** and **Left** arrow keys to move from one digit of the gas-concentration value to the other, with the first digit changing the tens and the second digit changing the units.

The user can end the simulation by pressing **ESC**.

---

**⚠** Alarm management operates as per usual during a simulation. This means that, if the simulated gas concentration exceeds an alarm threshold, the alarm is triggered and the associated outputs are activated, along with the servos connected to them.

---

## 5.2.4 Switching to the Battery

Navigation :

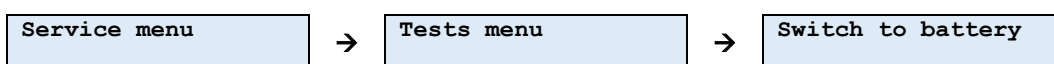

This test forces the U•V6 unit to switch to battery power, as if there were a mains power outage.

The user can activate this function by pressing the **ENTER** key. The system then asks for confirmation before switching the power source.

```

Switch to battery
Switch to battery ?
  
```

The user can confirm their request to switch power sources by pressing **ENTER**.

```

Switch to battery
Switched to battery
  
```

The U•V6 unit then reacts as if it were powered by the battery only:



- The **POWER** LED turns off
- The **BATTERY** LED lights up, but the power fault is not activated, i.e. the **FAULT** LED stays off.

This transition to battery-power operation is ended by one of the following:

- the user pressing **ESC**
- the menu idle time expiring.

## 5.3 Configuration Menu

### 5.3.1 Configuring the Measurement Channels

Once a measurement channel has been selected, the *Channels Menu* allows the user to do the following:

- assign a location to the detector
- set the detector to offline

#### a) Locating a Detector

Navigation :

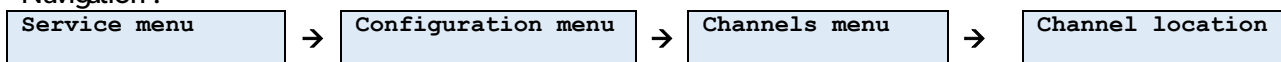

The location in the U•V6 unit allows the user to identify the detectors that are connected. By default, it is in the form **Detector x**, where x is the number for the detector input on the U•V6 unit.

The user may assign a location to a detector in two different ways:

- *Preset* Location
- *Custom* Location

These two methods may be combined by customising a location that has previously been chosen from the list of preset locations.

#### i) Preset Locations

The U•V6 unit proposes a list of preset locations. This is available in three languages (English, Dutch and French). For details of the list, see **Annex D : Predefined locations**

The user selects the location from the list using the **Up** and **Down** arrow keys.

When the title of the location allows it (display is limited to 20 characters), an index from 1 to 9 may be added using the **Right** and **Left** arrow keys. Depending on the item selected, it may also be possible to select other variants. See **Annex E: Characters available for text edition**

The user confirms their choice of location by pressing **ENTER**.

The user may interrupt and cancel their choice of location by pressing **ESC**.

#### ii) Custom Location

The location of a detector can be customised or completely modified. The U•V6 unit enters Location Edit Mode when the Custom Location function has been selected.

```
Location channel 3
Channel 3
```

The cursor flashes on the character being edited.

The **Up** and **Down** arrow keys allow the selected character to be edited.

The user confirms their choice of location by pressing **ENTER**.

The user can interrupt and cancel the editing of the location by pressing **ESC**.

b) Setting a Detector to « Out of order »

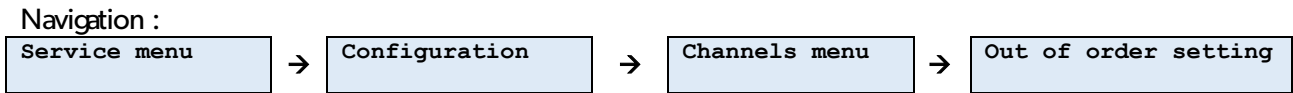

It may be useful to set a detector to offline while waiting for an authorised person to carry out a maintenance operation. When the **Out of order** function has been selected, the U•V6 unit shows the current status of the selected detector.

```
Out of order setting
Enabled
```

The user can set the detector to “Out of order” by pressing **ENTER**. Confirmation is then requested.

```
Out of order setting
Put out of order ?
```

The user confirms that the detector should be set to offline by pressing **ENTER**. The technical-fault relay then switches on if it has not already switched.

```
Out of order setting
Out of order
```

The user may interrupt and cancel the procedure for setting the detector to offline at any time by pressing **ESC**. The configuration menu for the selected detector is then enabled once more.

The user can set a detector to online again in the same way.

---

**⚠** A detector being “out of order” is considered to be a technical fault. This means that the fault relay switches!

---

### 5.3.2 Network Configuration

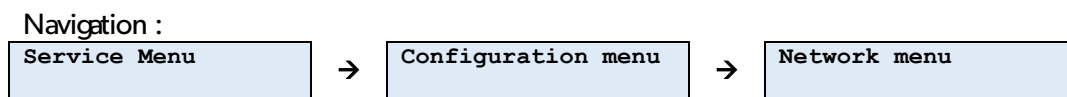

This menu is only available if the ethernet interface has been enabled. This allows the user to modify the following:

- the IP address of the U•V6 unit
- the IP address of the network gateway

The network configuration for the U•V6 unit is relatively streamlined. It is intended to work on a private network with mask 255.255.255.0. This means that only the last byte of the IP address of the gateway can be configured (the first three bytes are identical to the IP address and automatically updated).

---

**i** This menu is only available if the network interface has been enabled. The network interface may only be enabled by a technician certified by **DALEMANS**.

---

It should be noted that a Network Link Down fault is displayed if the ethernet interface of the U•V6 unit has been enabled and there is no connection upon start-up:

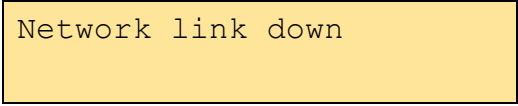

```
Network link down
```

This fault is not critical and the technical-fault relay does not switch. The user can press **Reset** twice to clear the message from the screen. The ethernet interface is not operational in this case. If a cable has just been connected to it, the U•V6 unit should be restarted.

#### a) The IP Address of the Unit

Once this function has been selected, the IP address of the U•V6 unit is displayed in edit mode. The cursor flashes on the digit being edited:

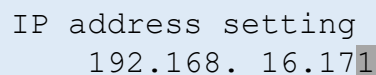

```
IP address setting
192.168. 16.171
```

The **Up** and **Down** arrow keys change the value of the digit being edited.

The **Right** and **Left** arrow keys allow the user to move from one digit in the IP address to the next. The first digit of each byte allows the user to modify the hundreds, the second digit allows the user to modify the tens and the third digit allows the user to modify the units.

Pressing **ENTER** ends the editing process for the network address. Confirmation is then requested:

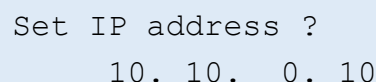

```
Set IP address ?
10. 10. 0. 10
```

The user can cancel the modification and return to the info menu by pressing **ESC**.

Pressing **ENTER** confirms the configuration of the network address.

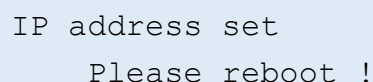

```
IP address set
Please reboot !
```

- 
- ❗ The editing of a network-configuration item requires the U•V6 unit to be restarted in order for it to take effect. This is why a request for the unit to be restarted is displayed.
  - ❗ The unit does not need to be restarted after editing each network-configuration item individually. Several items may be edited before the U•V6 unit is restarted.
- 

#### b) Network Gateway IP Address

The procedure for configuring the IP address for the network gateway is identical to the procedure for configuring the IP address for the U•V6 unit, except for the fact that only the last byte of the address can be edited. Since the network configuration has been streamlined, the first three bytes are identical to those of its IP address.

- 
- ❗ The editing of a network-configuration item requires the U•V6 unit to be restarted in order for it to take effect. This is why a request for the U•V6 unit to be restarted is displayed.
  - ❗ Several items may be edited before restarting the U•V6 unit.
- 

Those parameters allow to establish a connection with the U•V6 control unit using **MODBUS TCP**.

- 
- ❗ More more information on the configuration and usage of the interface, please refer to ***U•Line Modbus Interface Manual*** document.
- 

## 5.4 Maintenance Management

The maintenance menu allows the user to configure the functions associated with the maintenance-management alert, i.e.:

- the maintenance interval
- renewing the detector-calibration validity.

---

⚠ It is recommended that you maintain your installation on a yearly basis in order to guarantee optimal monitoring. The user is therefore **strongly discouraged** from changing the value of this interval.

---

- ❗ The maintenance alert does not indicate a system malfunction but is merely a reminder. However, renewing the detector-calibration validity may have a significant impact on the gas-detection function and may cause the unit to not work properly if the detector is not correctly calibrated any more.
-

## 5.4.1 Maintenance Interval

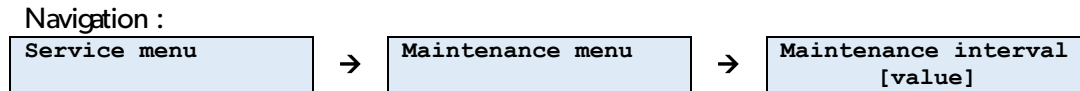

By default, the maintenance interval of detectors is set at **13 months**.

It may be useful to adapt the maintenance interval under some conditions (specific atmospheres, set or variable temperature and humidity conditions, etc.). It can be edited to be any interval ranging from **3** to **26 months**.

Once the maintenance-interval modification has been selected, the current interval configured in the U•V6 unit is displayed and the cursor flashes on the first digit of the value in months (the tens).

```
Maintenance interval
 13 months
```

The user can change the interval value using the **Up** and **Down** arrow keys.

The user can use the **Right** and **Left** arrow keys to move from one digit of the interval value to the other, with the first digit changing the tens and the second digit changing the units.

The user can select the value chosen for the calibration interval using the **ENTER** key. Confirmation is requested.

```
Set interval ?
 09 months
```

The user can **confirm the modification** of the calibration interval by pressing **ENTER**. The user can cancel the modification and return to the info menu by pressing **ESC**.

---

**i** In the event that a battery has been installed, a maintenance alert is also generated after four years. This interval cannot be modified.

---

## 5.4.2 Renewing the Validity of the Calibration.

Usually, the validity of the calibration settings for a detector are renewed automatically when it is calibrated by a technician certified by **DALEMANS sa/nv**. The maintenance interval for the calibrated detector is then reset.

In some specific cases, a detector may need to be verified by a certified control authority and the validity of the calibration of this detector may then be extended.

The user can select the detector for which the validity of the calibration is to be renewed using the **Up** and **Down** arrow keys. Each detector is displayed with the number of days that have lapsed since its last calibration and the full-scale value of the gas concentration that the detector is able to estimate.

```
1.Detector 1
 346 days    98%LEL
```

The user can confirm their selection of detector by pressing **ENTER**. The system then asks the user to confirm the renewal of the validity of the calibration for the selected detector.

```
1.Detector 1
  Renew calibration ?
```

The user can confirm the renewal of the validity of the calibration for the detector by pressing **ENTER**. The next maintenance date may have been modified at this point. The user can cancel the modification and return to the info menu by pressing **ESC**.

## 6 SPARE PARTS AND OPTIONS

---

A list of available spare parts that can be purchased is given below:

Designation	Item reference
U•V6 unit (without battery)	03084
U•V6 cover with display	03088
U•V6 motherboard	03130
Flat IDC female cable, 20-track IDC base, 5.91", 300 mm, step 2.54	00793
Housing for U•Line unit (base)	01036
Feet kit for fixing U•Line units	01040
DIN rail fixing kit for U•Line units	01041
Standard battery kit for U•Line units	00939

## 7 TARGET GASES

The U•V6 unit allows the user to detect the following gases:

Gas*	Range of Measurement	Formula	Density (air = 1)	CAS No.	Position
Methane (CNG)	100% LEL	CH <sub>4</sub>	0,55	74-82-8	Floor
Propane	100% LEL	C <sub>3</sub> H <sub>8</sub>	1,56	106-97-8	Floor
Butane	100% LEL	C <sub>4</sub> H <sub>10</sub>	2,05	74-98-6	Floor
LPG	100% LEL	(Mélange propane + butane)	-	-	Floor
Carbon monoxide	300ppm	CO	0,97	00630-08-0	1.5 meter high
Nitrogen dioxide	30ppm	NO <sub>2</sub>	1,58	10102-44-0	1.5 meter high
Hydrogen Fluoride	10ppm	HF	-	231-634-8	Floor
Carbon dioxide	5000ppm 4% vol. 5% vol.	CO <sub>2</sub>	1,53	00124-38-9	Floor
Oxygen	25% vol.	O <sub>2</sub>	1		1.5 meter high
Ammonia	100ppm 1000ppm 5000ppm	NH <sub>3</sub>	0,59	07664-41-7	Ceiling
Hydrogen Sulphide	100ppm 200ppm	H <sub>2</sub> S	1,19	07783-06-4	Floor
Sulphur dioxide	20ppm	SO <sub>2</sub>	2,26	07446-09-5	Floor
Chlorine	10ppm	Cl <sub>2</sub>	2,49	07782-50-5	Floor
Ozone	1ppm	O <sub>3</sub>	1	10028-15-6	1.5 meter high

\*This list is not exhaustive



# 8 PRODUCT SPECIFICATIONS

This product has been designed and manufactured in Belgium according to the quality charter of **Dalemans sa/nv**.

U•V6 control unit		
<b>Power supply</b>	Mains	220-240 V ~ (AC) 50Hz
	Power	20 W max.
	Overvoltage category	Category II
	Smart battery management	12 V (DC) auto-adaptive - 500mA max.
	Autonomy in sleep mode	4h with battery 2.3 Ah
<b>External circuits isolation</b>	Primary-secondary isolation	3600 Vrms
	Relays isolation between contacts and coil	4000 V (AC)
	Ethernet transformer isolation	1500 Vrms
<b>Enclosure</b>	Material	Plastic ABS-PC UL 94 V-0
	Dimensions (excluding PE)	265 x 230 x 125 mm
	Weight without battery	1,5 kg
	Ingress Protection - Pollution degree	IP65 – degree 2
	Reversibility	Rotation of 180°
	Location of backup battery	Standard format 2.3 Ah
	Standard mounting	4 screws or mounting lugs
	Optional mounting	Mounting on DIN rail
<b>Connection</b>	Cable inlets	11 x M20 and 8 x M16
	Screwed terminals	1 x 2.5 mm <sup>2</sup> or 2 x 1.5 mm <sup>2</sup> per terminal
<b>Inputs</b>	Detectors	6
	Type pf detector	4..20mA Current loop detectors from Dalemans product range
	Wiring length	Up to 300 m
	Self-powered external alarm input 24V (DC)	1
<b>Outputs</b>	Alarms: Addressable changeover relays Max. 230V / 3A	5
	Fault: changeover relay Max. 230V / 3A	1
	Alarm repeater: relay Max. 230V / 3A	1
	Transistor alarm	24 V (DC) - 200 mA max.
	Digital interface	Modbus TCP via Ethernet
<b>Interface</b>	Display	LCD backlighting of a variable colour
	Power indicator	Green LED
	Battery indicator	Green LED
	Inhibition indicator	Yellow LED
	Fault indicator	Yellow LED
	Navigation and configuration	Using a membrane keypad
<b>Main features</b>	Technical fault indicator	Up to 4 by target gas
	Navigation and configuration	YES
	Configurable alarm levels	YES
	Access protection using password	YES
	Maintenance alert	YES
	Display of events and statuses	YES
<b>Operating conditions</b>	Temperature	-10°C to +40°C
	Test and inhibition functions	10 to 90% RH (non-condensing) 90-110kPa
	Altitude	Max. 2000 m
<b>Certifications</b>	Standard for the detection of toxic gases in car parks	EN 50545-1 (ongoing)
	Electromagnetic compatibility (EMC)	EN 50270 (type 1)
	Low-voltage safety	EN 61010-1
	Software and digital technology standard	EN 50271 (ongoing)
	Marking	CE, RoHS

The information contained in this document is non-contractual and subject to change.

## A. EVENT MESSAGES

---

MESSAGE
No Event
System startup
Activated
Reset
Reset alarms action
Reset errors action
History cleared
Menu timeout expired
Configuration saved
Date & time setting
System date saved
Calibration starts
End of calibration
Calibration saved
Calibration failure
Calibration timeout
Calibration cancelled
Maintenance interval setting
Calibration data renewed
Calibration age saved
Channel enabled
Channel disabled
Channel out of order
Channel in order
Enabled
Disabled
Set location preset
Set custom location
Set standard setup
Language modified
User configuration level
Technician configuration level
Factory configuration level
Invalid password entered
Maintenance requested
Battery change needed
Start test
End of test
Test timeout
Outputs inhibited
Outputs de-inhibited
Simulation started
Simulation stopped
Switch to battery
Switch back to AC supply
Unset battery
New battery installed
Battery age reset

## MESSAGE

New alarm level 1 threshold

New alarm level 2 threshold

New Alarm level 3 threshold

New Alarm level 4 threshold

New failsafe configuration

Latching mode changed

Latching mode changed for level 1 alarms

Latching mode changed for level 2 alarms

Latching mode changed for level 3 alarms

Latching mode changed for level 4 alarms

Not addressed by external alarm

Addressed by external alarm

Addressed as siren by external alarm

Alternate name changed

Siren addressing changed

Normal state changed

Configuration changed

Sensors detection

Sensor detected

No sensor detected

Sensors detection interrupted

The network interface is activated

The network interface is disabled

The IP address is changed

The gateway IP address is changed

The way the errors are reset is changed

System configuration updated

Core configuration updated

System halted

System restarted

ADC reset

Password changed

Calibration renewal authorized

Calibration renewal not authorized

Set new gas type

New gas configuration

New alarm level 1 type

New alarm level 2 type

New alarm level 3 type

New alarm level 4 type

Enable alarm level 1

Enable alarm level 2

Enable alarm level 3

Enable alarm level 4

Disable alarm level 1

Disable alarm level 2

Disable alarm level 3

Disable alarm level 4

## MESSAGE

Addressing of alarm relay changed

Addressing from the measurement channel changed

Not addressed by fault

Addressed by fault

Addressed as siren by fault

Not addressed by power failure

Addressed by power failure

Addressed as siren by power failure

Modbus connection

Modbus disconnection

Disable analog output

Set analog output to 0..20 mA

Set analog output to 4..20 mA

Change analog output gain

Factored in the analog output

Not factored in the analog output

## B. ERROR MESSAGES

MESSAGE	PROBABLE CAUSE	TROUBLESHOOT
No error	-	-
Flash memory integrity error	Troubles occurred with the non-volatile memory	U•V6 control unit maintenance
Display not ready	Troubles occurred with the display board	U•V6 control unit maintenance
Display initialization error		
Display error		
Keys & leds not ready		
Keys & leds initialization error		
EEPROM not ready		
EEPROM reading error	An operation with the EEPROM failed	U•V6 control unit maintenance
EEPROM integrity error		
EEPROM writing error		
Date saving error		
Lowest temperature saving error		
Highest temperature saving error		
Temperatures saving error		
Password loading error		
Password saving error		
Password update error		
Date & time setting error	The operation failed	Retry. If the error is persistent, U•V6 control unit maintenance
System configuration initialization error	Something went wrong during initialization	Reboot. If the error is persistent, U•V6 control unit maintenance
Core configuration load error		
History initialization error		
Date initialization error		
ADC calibration error	Data acquisition failed	U•V6 control unit maintenance
ADC conversion (internal) error		
ADC conversion (config.) error		
ADC conversion (DMA) error		
ADC conversion timeout		
Power failure	The U•V6 control unit is not correctly supplied by the main power	Check the the main power supply
Battery missing	The U•V6 control unit does not view the battery	U•V6 control unit maintenance
Battery low voltage	The battery need to be charged. The main power supply is expected	If the error is persistent, U•V6 control unit maintenance
Battery discharged	The battery need to be charged. The main power supply is expected. The control unit shall halt	If the error is persistent, U•V6 control unit maintenance
Defective battery	The battery cannot be managed by the control unit	U•V6 control unit maintenance

MESSAGE	PROBABLE CAUSE	TROUBLESHOOT
Invalid core configuration	Something went wrong in memory	U•V6 control unit maintenance
Corrupted core configuration		
Corrupted calibration data		
Corrupted system configuration		
Corrupted password		
Corrupted info (PS)		
Corrupted info (core)		
Corrupted info (system)		
Corrupted info (error)		
Corrupted password loaded		
Network link down	A network connection is expected. The fault relay is not affected	Check the network connection. Once the problem is solved, the U•V6 control unit must be restarted
All channels disabled	No channel is active. The control unit is unemployed	Connect a gas detector and proceed to a detector detection
External alarm inhibited	The external alarm can no more be managed (mainly due to a power supply failure)	If another trouble is observed, resolve it first. If the error is persistent, U•V6 control unit maintenance
System configuration update failure	-	For technician only
Core configuration update failure		
Calibration renewal authorize failure	The operation failed	Retry. If the error is persistent, U•V6 control unit maintenance
Sensor error	The detector is in error	Check the detector and its connection to the U•V6 control unit
Out of order	The detector has been put out of order	For technician only Detector maintenance
Calibration timeout	The detector calibration failed for the given reason The fault relay is not affected	Retry. If the error is persistent, U•V6 control unit maintenance
Calibration failed		
Calib. interrupted		

## C. PREDEFINED LOCATIONS

---

ENGLISH TEXT	TEXTE FRANÇAIS	NEDERLANDSE TEKST
Detector	Détecteur	Detector
Bike park	Parking vélo	Fiets parking
Car park	Parking	Parkeerplaats
Car park +1 p1	Parking +1 p1	Parkeerplaats +1 p1
Car park rez p1	Parking rez p1	Parkeerplaats gelijkvloers +1 p1
Clark room	Local clark	Clark-kamer
Bat. charge room	Local chargeur bat	Bat. laadlokaal
Heater room	Local chaufferie	Verwarmingsruimte
Lab	Labo	Lab
Level	Niveau	Level
Ramp	Rampe	Ramp
Room	Pièce	Lokaal
Tunnel	Tunnel	Tunnel
Tunnel lhs p1	Tunnel droite p1	Tunnel rechts p1
Tunnel mid p1	Tunnel milieu p1	Tunnel midden p1
Tunnel rhs p1	Tunnel gauche p1	links tunnel p1
Zone	Zone	Zone

## D. CHARACTERS AVAILABLE FOR TEXT EDITION

---

- The numbers **0 - 9**
- The letters of the **alphabet lowercase**
- The letters of the **alphabet in uppercase**
- **Vowels with accents** and **ç** in lowercase
- The **dash** and the special character **@**



# E. USER MENU DIAGRAM

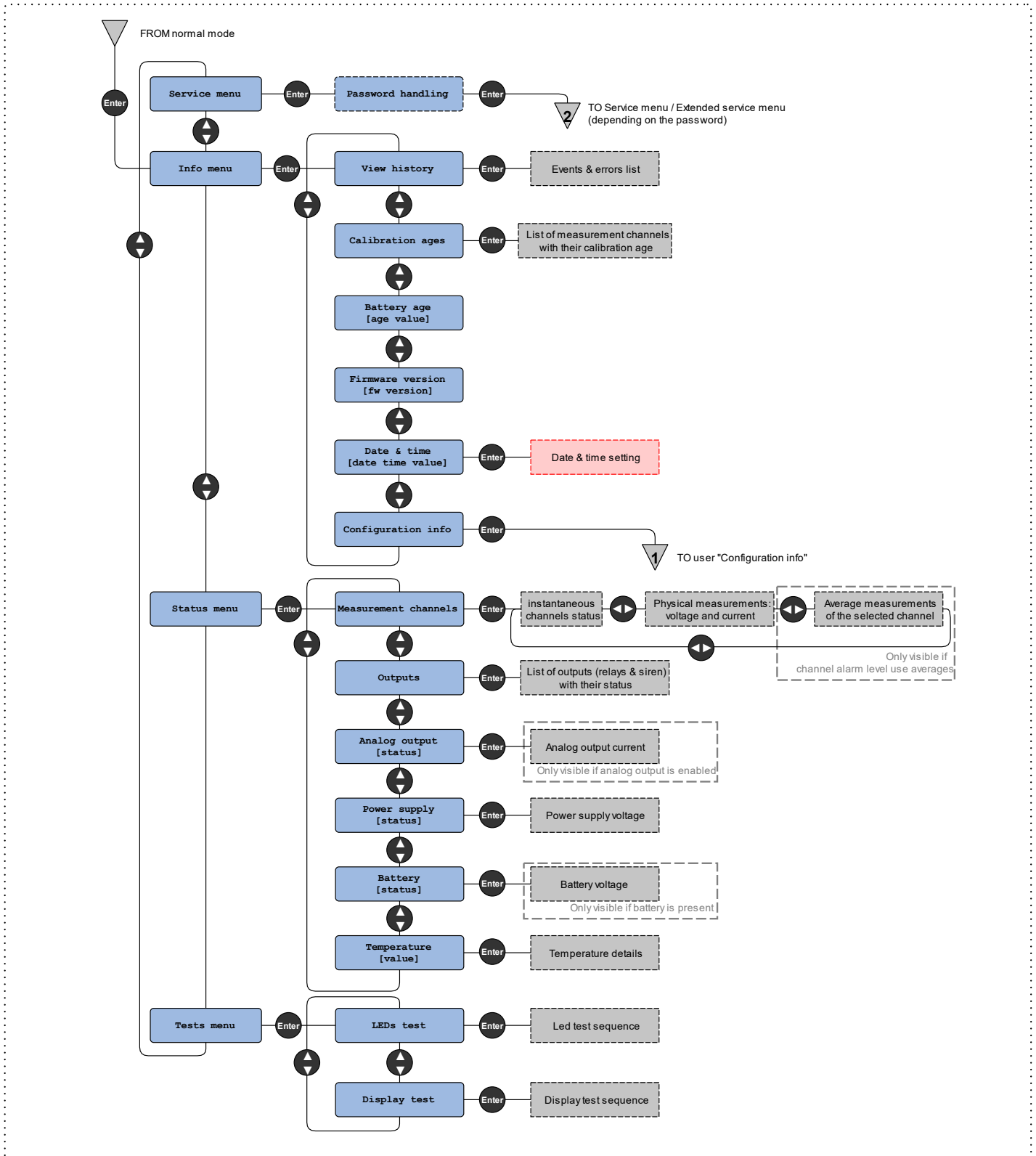

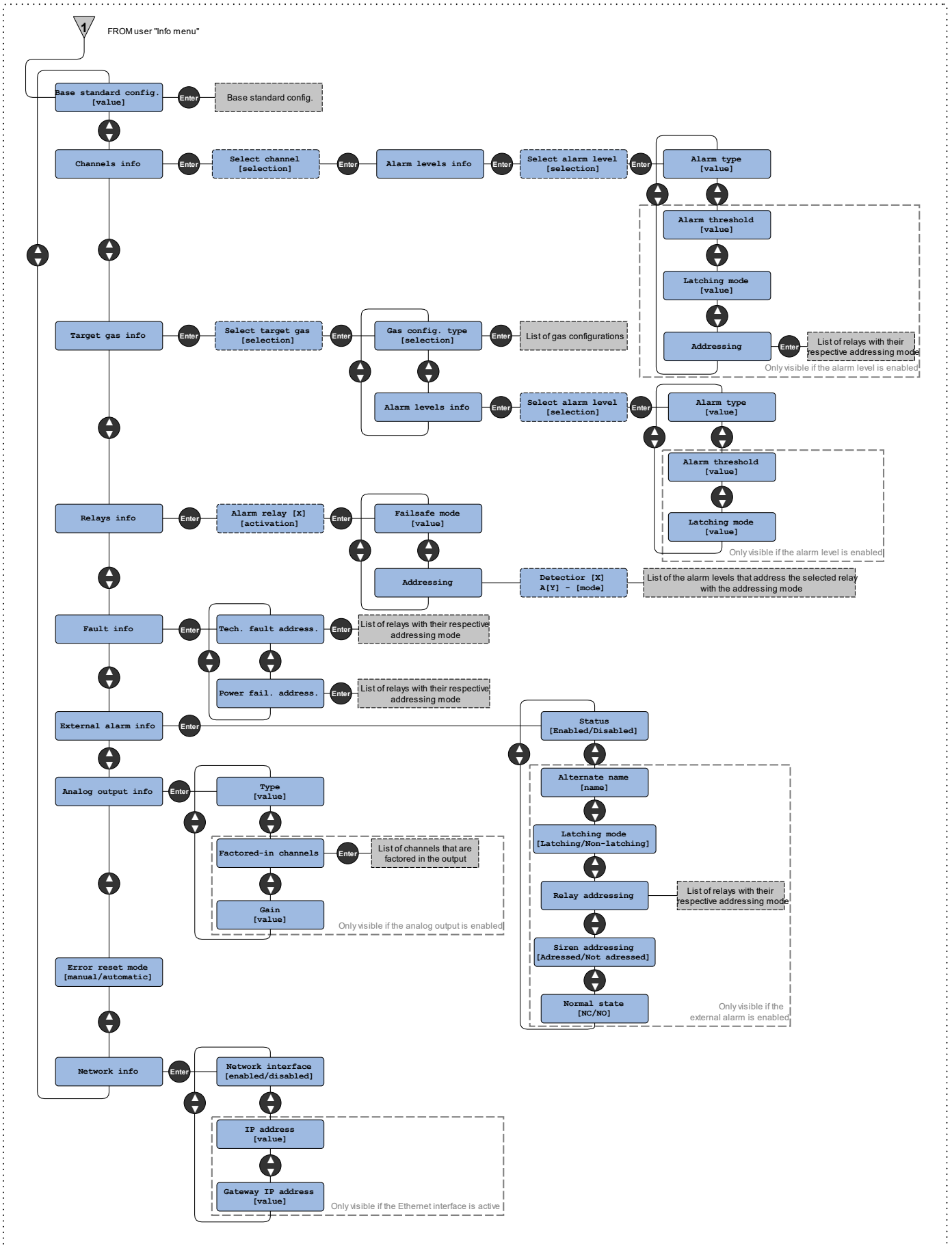

# F. SERVICE MENU DIAGRAM

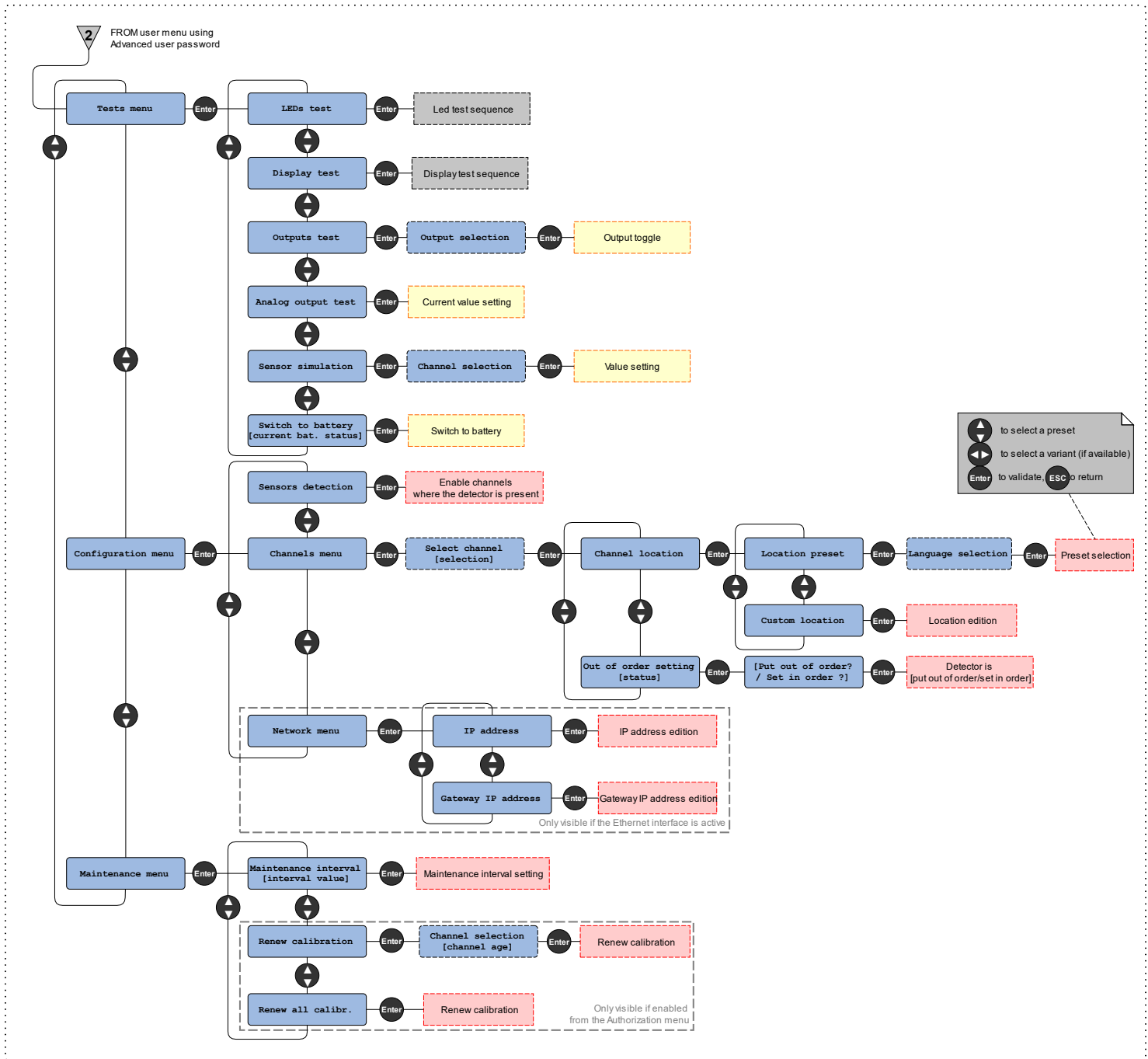



ALARM CONTROL UNIT FOR  
TOXIC & FLAMMABLE GASES

# INSTRUCTION MANUAL

**DALEMANS<sup>®</sup>**

G A S D E T E C T I O N

rue Jules Mélotte 27A | B-4350 Remicourt (Belgium)  
+32 19 33 99 43 | sales@dalemans.com

[www.dalemans.com](http://www.dalemans.com)